

# Technischer Datenblatt Katalog

**2024/1**



+90 533 651 17 66



info@armaluminyum.com



www.armaluminyum.com



Çerkeşli mevki imes osb 9.cadde no 19 dilovası  
kocaeli



# INHALTSVERZEICHNIS

<b>Dachsysteme</b> .....	05
• Dachhaken Dark SRVH2 Schwarz Eloxiert Set	06
• Dachhaken Main SRVH2 Blank Set	07
• Dachhaken Singel SRVH2 Blank Set	08
• Dachhaken Vario Blank Set	09
• Alu Dachhaken Click Blank	10
• Dachhaken Cross Blank Set ( Horizontale Modul Belegung )	11
• Dachhaken Cross Schwarz Eloxiert Set ( Horizontale Modul Belegung )	12
• Dachhaken Easy SRVH2 Blank Set	13
<b>Profile</b> .....	15
• Montageschiene Blank 4740 ( L=4900 mm)	16
• Montageschiene Schwarz Eloxiert 4740s ( L=4900 mm)	17
• Schienenverbinder Blank ( 200mm )	18
• Schienenverbinder Schwarz Eloxiert ( 200 mm )	19
• Aluhalteplatte 4900 mm ohne Bohrung	20
• Kurzschiene ohne Bohrung und EPDM (L= 5000 mm)	21
• Montageschiene Blank 4027 ( L=4900 mm )	22
• Montageschiene 4027 Schwarz Eloxiert	23
• Montageschiene Blank 5027 ( L=4900 mm )	24
• Montageschiene Schwarz Eloxiert 5027 ( L=4900 mm )	25
<b>Mittel und Endklemmen</b> .....	27
• Endklemme Schwarz Eloxiert 35 mm Set	28
• Endklemme Schwarz Eloxiert mit Erdungspin 35mm Set	29
• Endklemme Blank 35 mm Set	30
• Endklemme mit Erdungspin 35 mm Set	31
• Endklemme Blank 30 mm Set	32
• Endklemme Blank mit Erdungspin 30 mm	33
• Endklemme Schwarz Eloxiert 30 mm Set	34
• Endklemme Schwarz Eloxiert mit Erdungspin 30mm Set	35
• Mittelklemme Blank Set	36
• Mittelklemme Blank mit Erdungspin Set	37
• Mittelklemme Schwarz Eloxiert Set	38
• Mittelklemme Schwarz Eloxiert mit Erdungspin Set	39

<b>Sandwich / Trapez und Stehfalzdächern.....</b>	<b>41</b>
• Kurzschiene mit EPDM 415 mm.	42
• Flügeleklemme für Trapezdach mit EPDM Band	43
• Stehfalzklemme V1 Flach Set	44
• Stehfalzklemme V2 L-Winkel	45
• Stehfalzklemme V3 Round	46
• Flachdach EWB NEO	47
• Flachdach SB NEO	48
<b>PV Zubehör.....</b>	<b>49</b>
• Alu Halteplatte 850 mm mit Bohrung ( 1 x Links )	50
• Alu Halteplatte 160mm	51
• Kreuzverbinder II	52
• Mittelklemme Blank Universal	53
• Mittelklemme Universal Schwarz Eloxiert	54
• Alu Rundleiter Ø8mm ( 155 M )	55
• Endklemme Blank Z Form 30 mm	56
• Erdungsklemme M8 Set	57
• Kreuzverbinder M12	58
• Verstell-Winkel B75	59
• Verstell-Winkel B75S	60
• Endklemme Blank Z Form 35 mm	61
• Endklemme Schwarz Eloxiert Z Form 30 mm	62
• Endklemme Schwarz Eloxiert Z- Form 35 mm	63
• Abdeckkappen Schwarz für Montageprofil 4740 Set	64
• Abdeckkappen Grau für Montageprofil 4740 Set	65
• Alu-Gewindemuffe M32 für 2023106	66
• Alu-Steckmuffe M32 für Alu Steckrohr 2023106/1	67
• Alu-Gewinderohr ø31,8 mm ( L= 2500 mm )	68
• Alu-Rohr ø31,8 mm ( L= 2500 mm )	69
• Alu-Klemmschelle M32 für Alusteckrohr 2023106/1	70
• Montage Winkel für Profil 4740	71
• Bitumen Schweissteller	72

## **Dachsysteme**

# Technisches Datenblatt

## 231460 Dackhhaken Dark SRVH2 Schwarz Eloxiert Set

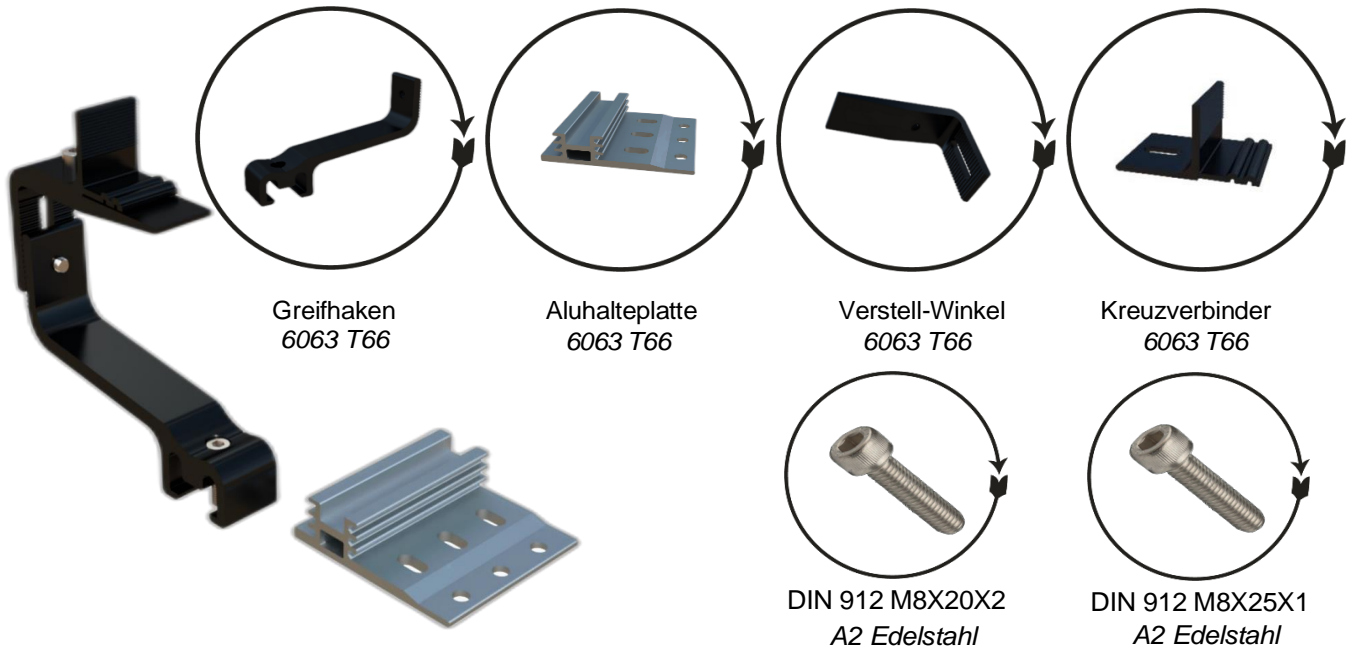

Art.Nr.	Bezeichnung	Material	Oberfläche	Stück/ Karton	Verpackung LXBXH	gr/ Stück
8113	Halteplatte	EN AW 6063 T66	Blank	20	60 X 40 X 10	219,5
8114-E	Greifhaken	EN AW 6063 T66	Schwarz Eloxiert	20		208,67
8115-E	Verstell-Winkel	EN AW 6063 T66	Schwarz Eloxiert	20		121,09
8256-E	Kreuzverbinder (M8)	EN AW 6063 T66	Schwarz Eloxiert	20		41,07
10102	Inbusschraube DIN 912 M8X20	A2	Edelstahl	40		14,24
10106	Inbusschraube DIN 912 M8X25	A2	Edelstahl	20		15,97

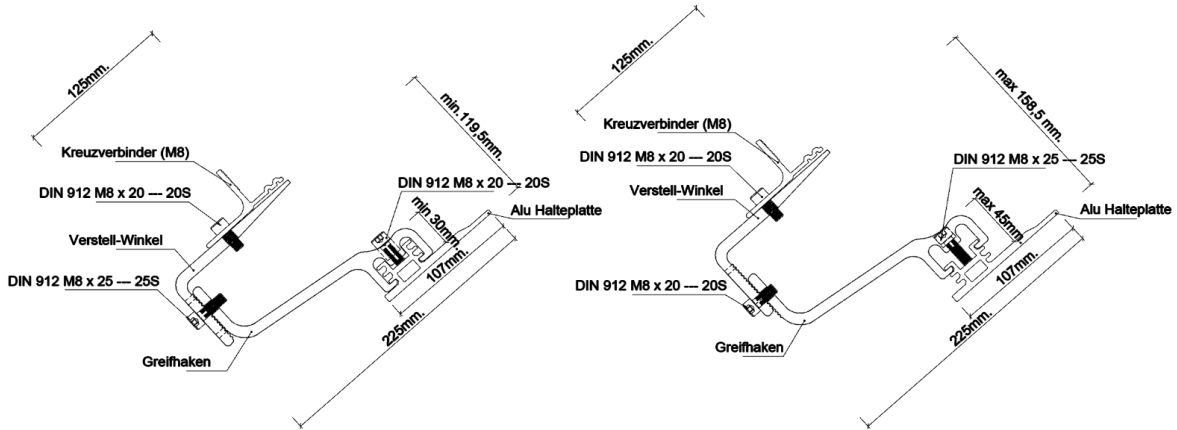

CERTIFICATE OF CONFORMITY OF THE FACTORY PRODUCTION CONTROL  
2674-CPR-233541

In compliance with Regulation (EU) No 305/2011 of the European Parliament and of the Council of 9 March 2011 (the Construction products Regulation od CPR), this certificate applies to the construction products.

CONSTRUCTION PRODUCT(S)

Scope of certificate : Aluminium and aluminium alloys-Structural products for construction Works

EN 150088:2005

under system 2+ are applied that

the factory production control is assessed to be conformity with the applicable requirements.

This certificate was first issued on <20.12.2023> and will remain valid as long as neither the harmonised standard, the construction product, the AVCP methods nor the manufacturing conditions in the plant are modified significantly, unless suspended or withdrawn by FQC Standard Uygunluk Degerlendirme A. Ş. The validity of the document is ensured by annual audits.

- Dimension and Shape Tolerances -Yield Strength -Tensile Strength -Elongation	Product	General Conditions	Specific Conditions		Dimensions	Alloy
			Mechanical Specifications	Tolerance		
	Extrude Profile	EN 755-1	EN 755-2	EN 755-9	Thickness min 0.9 mm. Thickness max. 20.0 mm.	EN AW 6060 EN AW 6063 EN AW 6463



# Technisches Datenblatt

## 231461 Dachhaken Main SRVH2 Blank Set

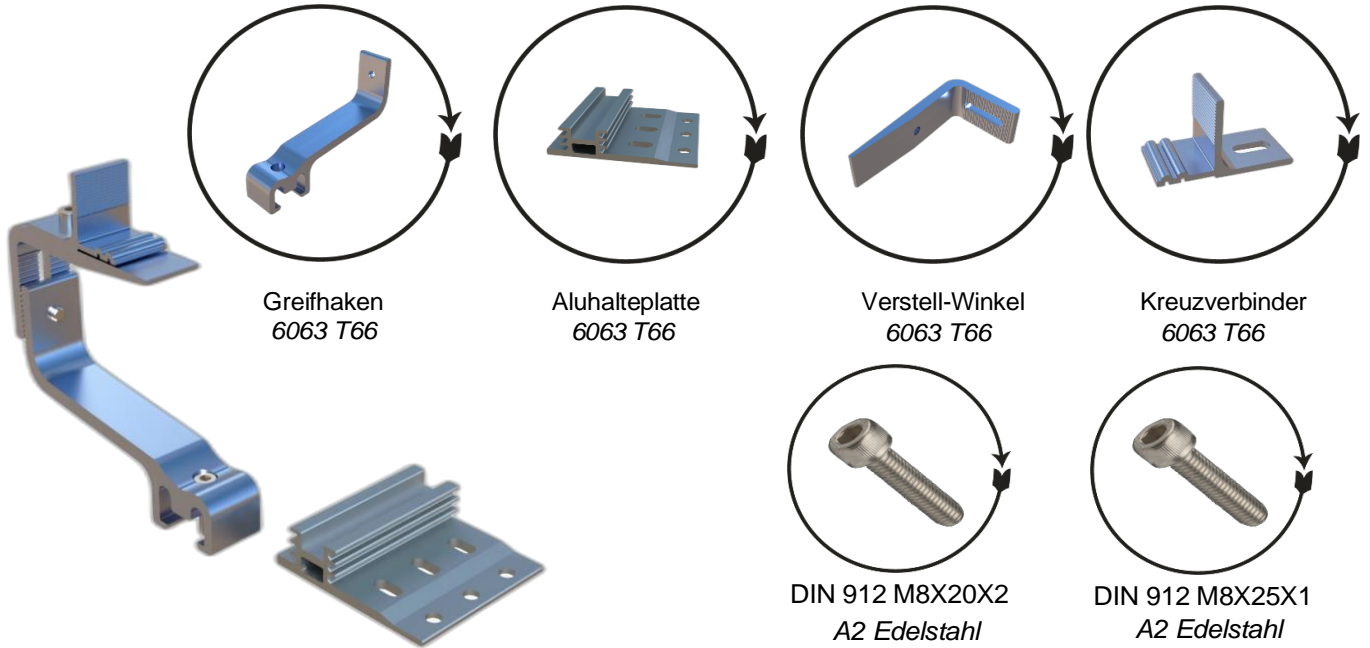

Art.Nr.	Bezeichnung	Material	Oberfläche	Stück/ Karton	Verpackung LXBXH	gr/ Stück
8113	Halteplatte	EN AW 6063 T66	Blank	20	60 X 40 X 10	219,5
8114	Greifhaken	EN AW 6063 T66	Blank	20		208,67
8115	Verstell-Winkel	EN AW 6063 T66	Blank	20		121,09
8256	Kreuzverbinder (M8)	EN AW 6063 T66	Blank	20		41,07
10102	Inbusschraube DIN 912 M8X20	A2	Edelstahl	40		14,24
10106	Inbusschraube DIN 912 M8X25	A2	Edelstahl	20		15,97

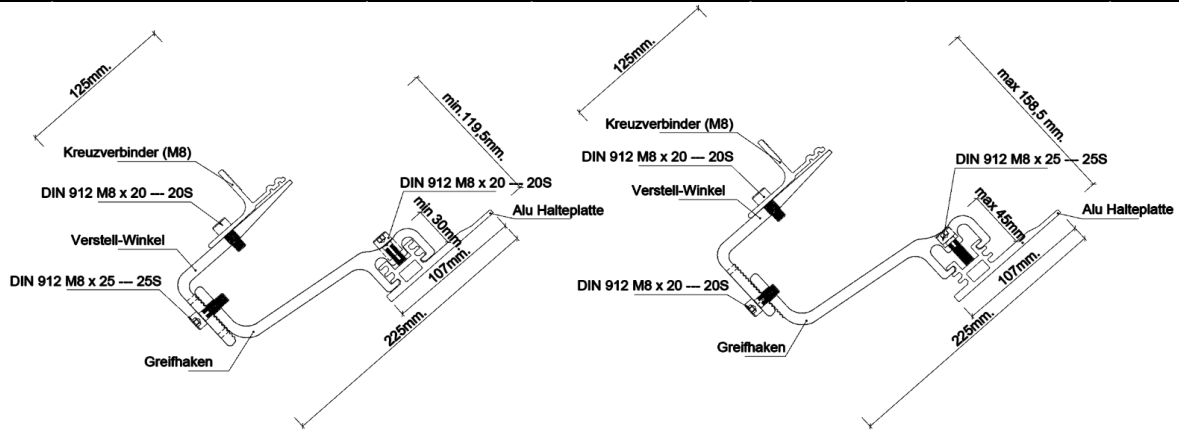

CERTIFICATE OF CONFORMITY OF THE FACTORY PRODUCTION CONTROL  
2674-CPR-233541

In compliance with Regulation (EU) No 305/2011 of the European Parliament and of the Council of 9 March 2011 (the Construction products Regulation od CPR), this certificate applies to the construction products.

CONSTRUCTION PRODUCT(S)

Scope of certificate : Aluminium and aluminium alloys-Structural products for construction Works

EN 150088:2005

under system 2+ are applied that

the factory production control is assessed to be conformity with the applicable requirements.

This certificate was first issued on <20.12.2023> and will remain valid as long as neither the harmonised standard, the construction product, the AVCP methods nor the manufacturing conditions in the plant are modified significantly, unless suspended or withdrawn by FQC Standard Uygunluk Degerlendirme A. Ş. The validity of the document is ensured by annual audits.

- Dimension and Shape Tolerances -Yield Strength -Tensile Strength -Elongation	Product	General Conditions	Specific Conditions		Dimensions	Alloy
			Mechanical Specifications	Tolerance		
	Extrude Profile	EN 755-1	EN 755-2	EN 755-9	Thickness min 0.9 mm. Thickness max. 20.0 mm.	EN AW 6060 EN AW 6063 EN AW 6463



## 231462 Dachhaken Singel SRVH2 Blank Set

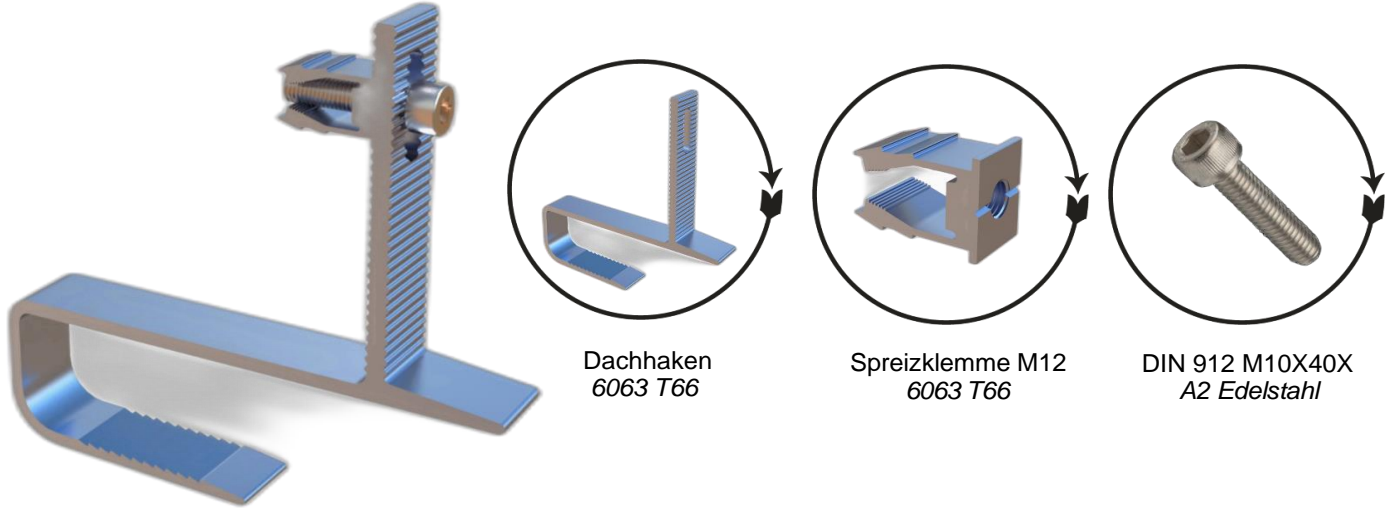

Dachhaken  
6063 T66

Spreizklemme M12  
6063 T66

DIN 912 M10X40X  
A2 Edelstahl

Art.Nr.	Bezeichnung	Material	Oberfläche	Stück/ Karton	Verpackung LXBXH	gr/ Stück
8116	Dachhaken	EN AW 6063 T66	Blank	20	60 X 40 X 10	190,95
9514	Spreizklemme M12	EN AW 6063 T66	Blank	20		15,85
10103	Inbusschraube DIN 912 M10X40	A2	Edelstahl	20		35,16

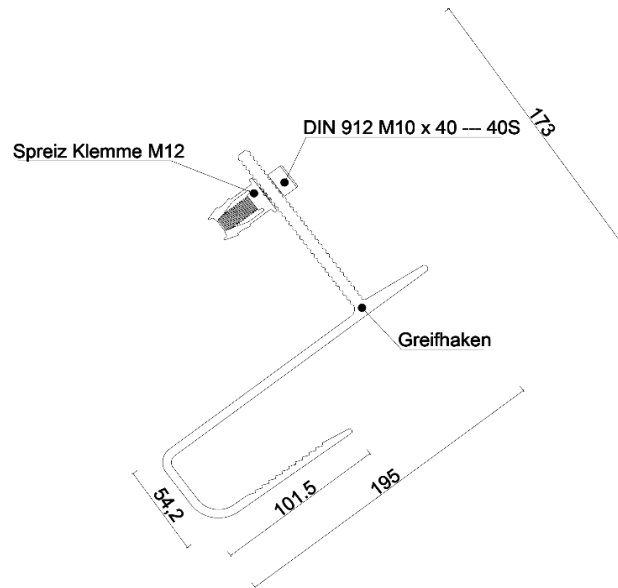

CERTIFIKATE OF CONFORMITY OF THE FACTORY PRODUCTION CONTROL  
2674-CPR-233541

In compliance with Regulation (EU) No 305/2011 of the European Parliament and of the Council of 9 March 2011 (the Construction products Regulation od CPR), this certificate applies to the construction products.

CONSTRUCTION PRODUCT(S)

Scope of certificate : Aluminium and aluminium alloys-Structural products for construction Works

EN 150088:2005

under system 2+ are applied that

the factory production control is assessed to be conformity with the applicable requirements.

This certificate was first issued on <20.12.2023> and will remain valid as long as neither the harmonised standard, the construction product, the AVCP methods nor the manufacturing conditions in the plant are modified significantly, unless suspended or withdrawn by FQC Standard Uygunluk Degerlendirme A. Ş. The validity of the document is ensured by annual audits.

- Dimension and Shape Tolerances -Yield Strength -Tensile Strength -Elongation	Product	General Conductions	Specific Conductions		Dimensions	Alloy
			Mechanical Specifinations	Tolarance		
	Extrude Profile	EN 755-1	EN 755-2	EN 755-9	Thickness min 0.9 mm. Thickness max. 20.0 mm.	EN AW 6060 EN AW 6063 EN AW 6463





# 231463 Dachhaken Vario Blank Set

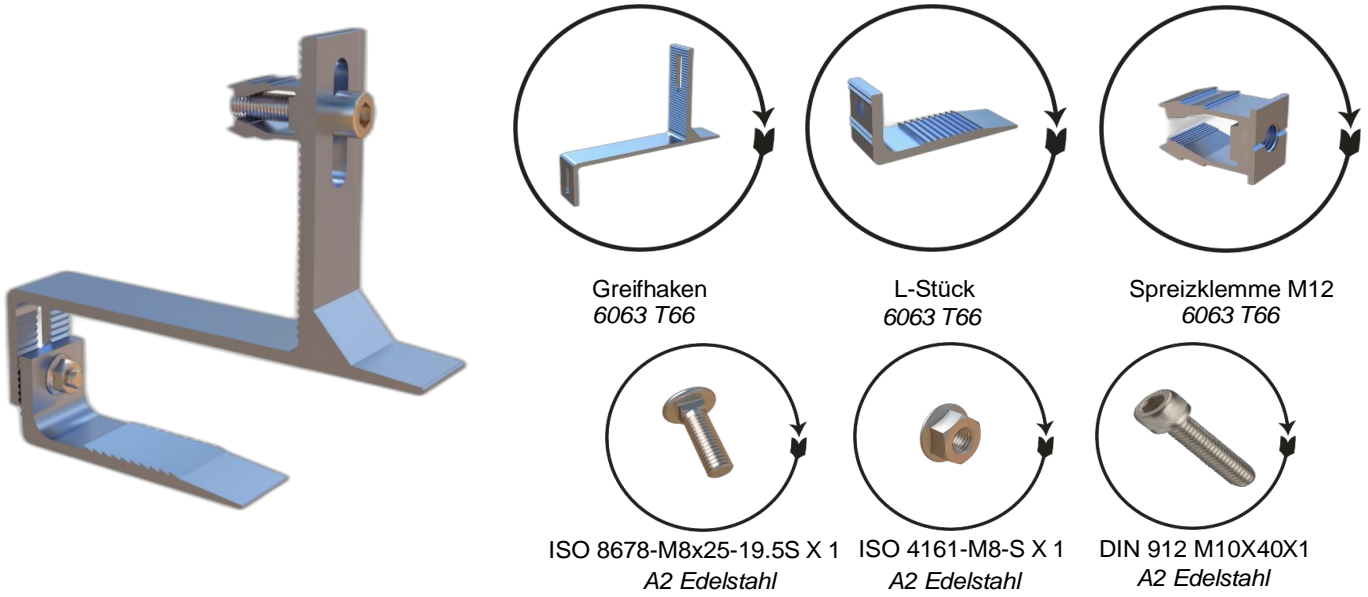

Art.Nr.	Bezeichnung	Material	Oberfläche	Stück/ Karton	Verpackung LXBXH	gr/ Stück
8117	Greifhaken	EN AW 6063 T66	Blank	20	60 X 40 X 10	183,58
8118	L-Stück	EN AW 6063 T66	Blank	20		76,99
10104	Vierkanthalschraube M8X25 ISO 8678-M8x25-19.5-S	A2	Edelstahl	20		15,63
10107	Flanschnutter M8 ISO 4161-M8-S	A2	Edelstahl	20		7,71
9514	Spreizklemme M12	EN AW 6063 T66	Blank	20		15,85
10103	Inbusschraube DIN 912 M10X40	A2	Edelstahl	20		35,16

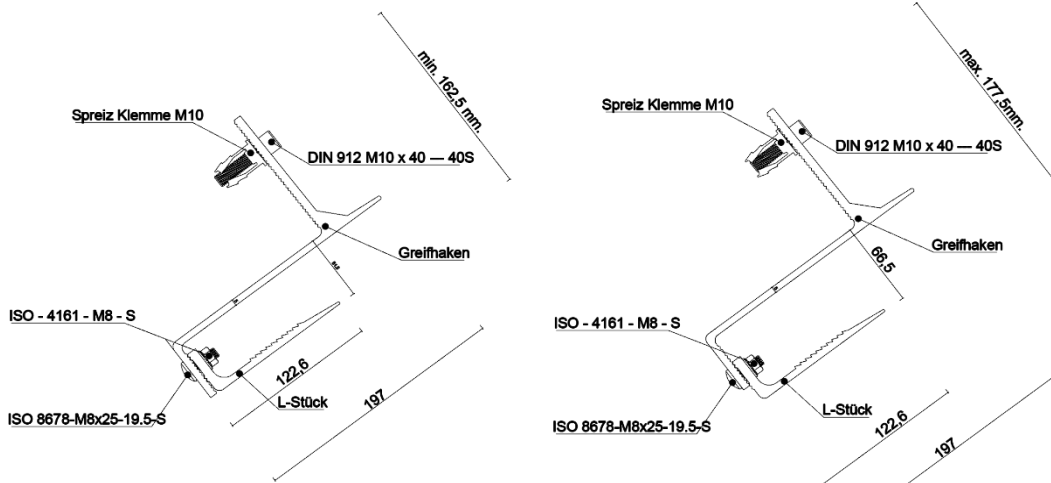

CERTIFIKATE OF CONFORMITY OF THE FACTORY PRODUCTION CONTROL  
2674-CPR-233541

In compliance with Regulation (EU) No 305/2011 of the European Parliament and of the Council of 9 March 2011 (the Construction products Regulation od CPR), this certificate applies to the construction products.

CONSTRUCTION PRODUCT(S)

Scope of certificate : Aluminium and aluminium alloys-Structural products for construction Works

EN 150088:2005

under system 2+ are applied that

the factory production control is assessed to be conformity with the applicable requirements.

This certificate was first issued on <20.12.2023> and will remain valid as long as neither the harmonised standard, the construction product, the AVCP methods nor the manufacturing conditions in the plant are modified significantly, unless suspended or withdrawn by FQC Standard Uygunluk Degerlendirme A. Ş. The validity of the document is ensured by annual audits.

- Dimension and Shape Tolerances -Yield Strength -Tensile Strength -Elongation	Product	General Conditions	Specific Conditions		Dimensions	Alloy
			Mechanical Specifications	Tolerance		
	Extrude Profile	EN 755-1	EN 755-2	EN 755-9	Thickness min 0.9 mm. Thickness max. 20.0 mm.	EN AW 6060 EN AW 6063 EN AW 6463



# Technisches Datenblatt

## 231464 Alu Dachhaken Click Blank

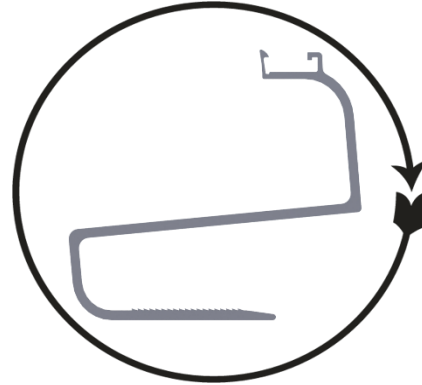
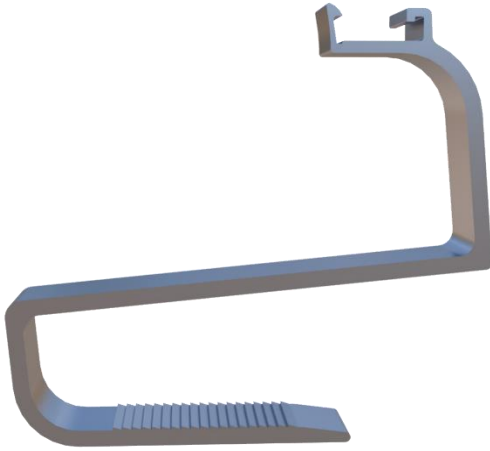

Alu Dachhaken Click  
6063 T66

Bezeichnung	Material	Oberfläche	Stück/ Karton	Verpackung LXBXH	gr/ Stück
Alu Dachhaken Click	EN AW 6063 T66	Blank	20	60 X 40 X 10	157,65

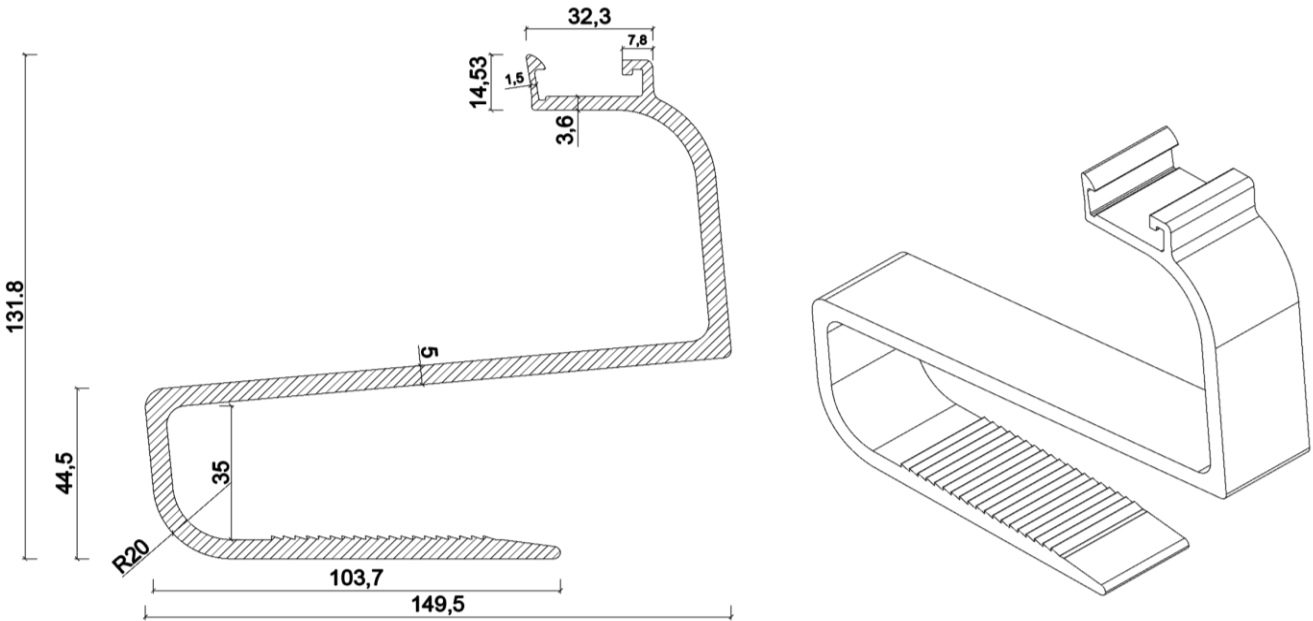

CERTIFIKATE OF CONFORMITY OF THE FACTORY PRODUCTION CONTROL  
2674-CPR-233541

In compliance with Regulation (EU) No 305/2011 of the European Parliament and of the Council of 9 March 2011 (the Construction products Regulation od CPR), this certificate applies to the construction products.

CONSTRUCTION PRODUCT(S)

Scope of certificate : Aluminium and aluminium alloys-Structural products for construction Works

EN 150088:2005

under system 2+ are applied that

the factory production control is assessed to be conformity with the applicable requirements.

This certificate was first issued on <20.12.2023> and will remain valid as long as neither the harmonised standard, the construction product, the AVCP methods nor the manufacturing conditions in the plant are modified significantly, unless suspended or withdrawn by FQC Standard Uygunluk Degerlendirme A. Ş. The validity of the document is ensured by annual audits.

- Dimension and Shape Tolerances -Yield Strength -Tensile Strength -Elongation	Product	General Conditions	Specific Conditions		Dimensions	Alloy
			Mechanical Specifications	Tolerance		
	Extrude Profile	EN 755-1	EN 755-2	EN 755-9	Thickness min 0.9 mm. Thickness max. 20.0 mm.	EN AW 6060 EN AW 6063 EN AW 6463



# Technisches Datenblatt

## 231465 Dachhaken Cross Blank Set ( Horizontale Modul Belegung )

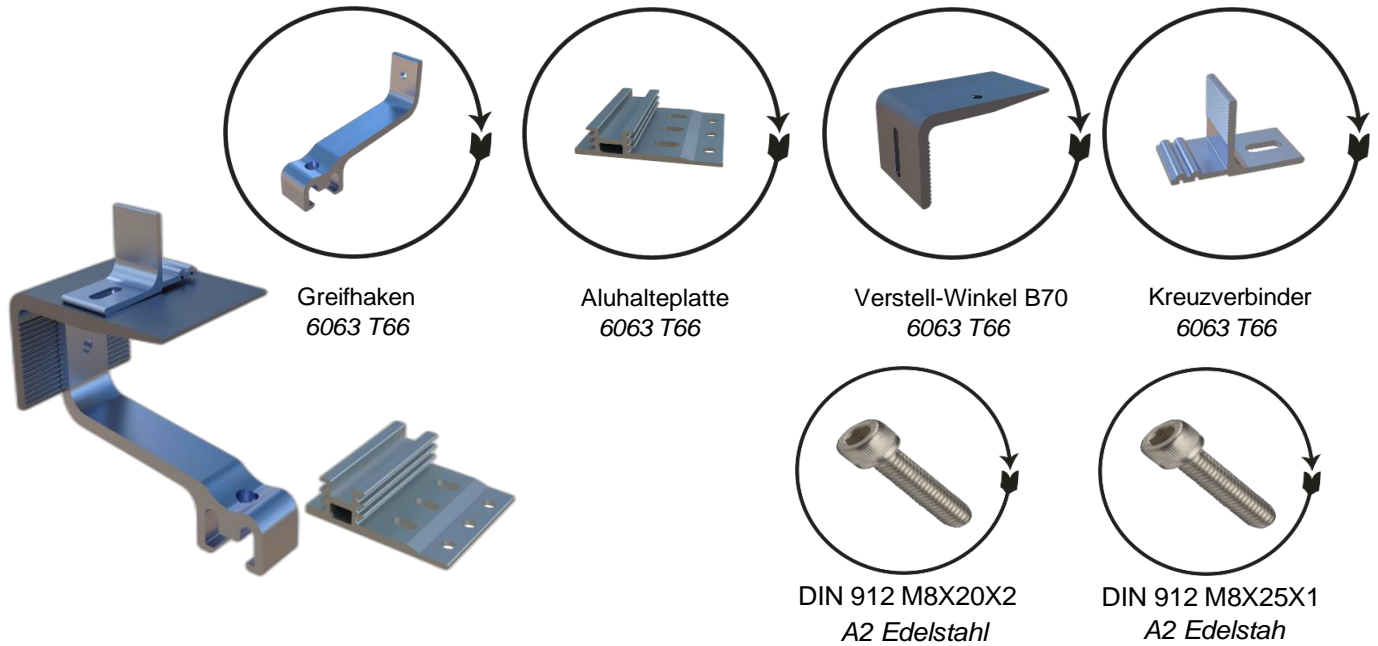

Art.Nr.	Bezeichnung	Material	Oberfläche	Stück/ Karton	Verpackung LXBXH	gr/ Stück
8113	Halteplatte	EN AW 6063 T66	Blank	20	60 X 40 X 10	219,5
8114	Greifhaken	EN AW 6063 T66	Blank	20		208,67
8115	Verstell-Winkel B70	EN AW 6063 T66	Blank	20		268,21
8256	Kreuzverbinder (M8)	EN AW 6063 T66	Blank	20		41,07
10102	Inbusschraube DIN 912 M8X20	A2	Edelstahl	40		14,24
10106	Inbusschraube DIN 912 M8X25	A2	Edelstahl	20		15,97

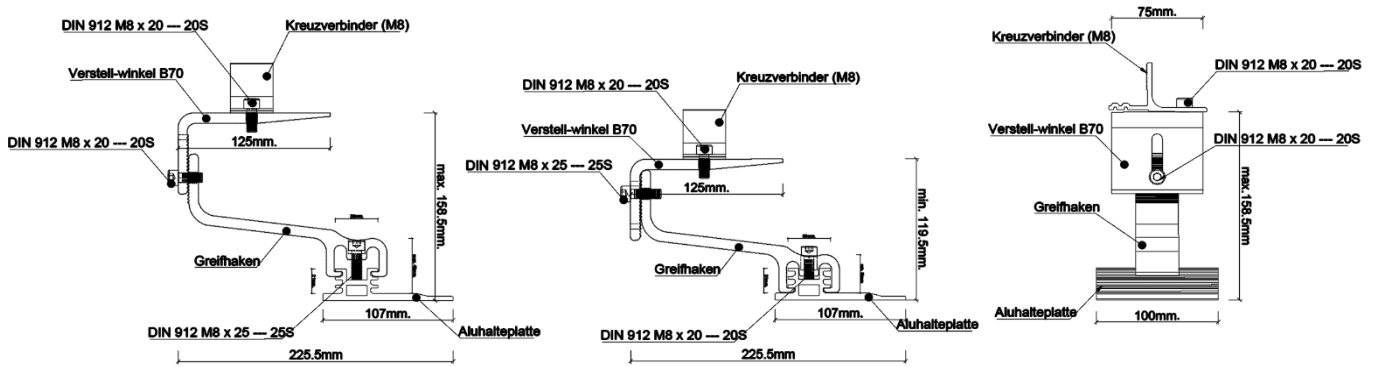

CERTIFICATE OF CONFORMITY OF THE FACTORY PRODUCTION CONTROL  
2674-CPR-233541

In compliance with Regulation (EU) No 305/2011 of the European Parliament and of the Council of 9 March 2011 (the Construction products Regulation od CPR), this certificate applies to the construction products.

CONSTRUCTION PRODUCT(S)

Scope of certificate : Aluminium and aluminium alloys-Structural products for construction Works

EN 150088:2005

under system 2+ are applied that

the factory production control is assessed to be conformity with the applicable requirements.

This certificate was first issued on <20.12.2023> and will remain valid as long as neither the harmonised standard, the construction product, the AVCP methods nor the manufacturing conditions in the plant are modified significantly, unless suspended or withdrawn by FQC Standard Uygunluk Degerlendirme A. Ş. The validity of the document is ensured by annual audits.

- Dimension and Shape Tolerances -Yield Strength -Tensile Strength -Elongation	Product	General Conditions	Specific Conditions		Dimensions	Alloy
			Mechanical Specifications	Tolerance		
	Extrude Profile	EN 755-1	EN 755-2	EN 755-9	Thickness min 0.9 mm. Thickness max. 20.0 mm.	EN AW 6060 EN AW 6063 EN AW 6463



# Technisches Datenblatt

## 231466 Dachhaken Cross Schwarz Eloxiert Set ( Horizontale Modul Belegung )

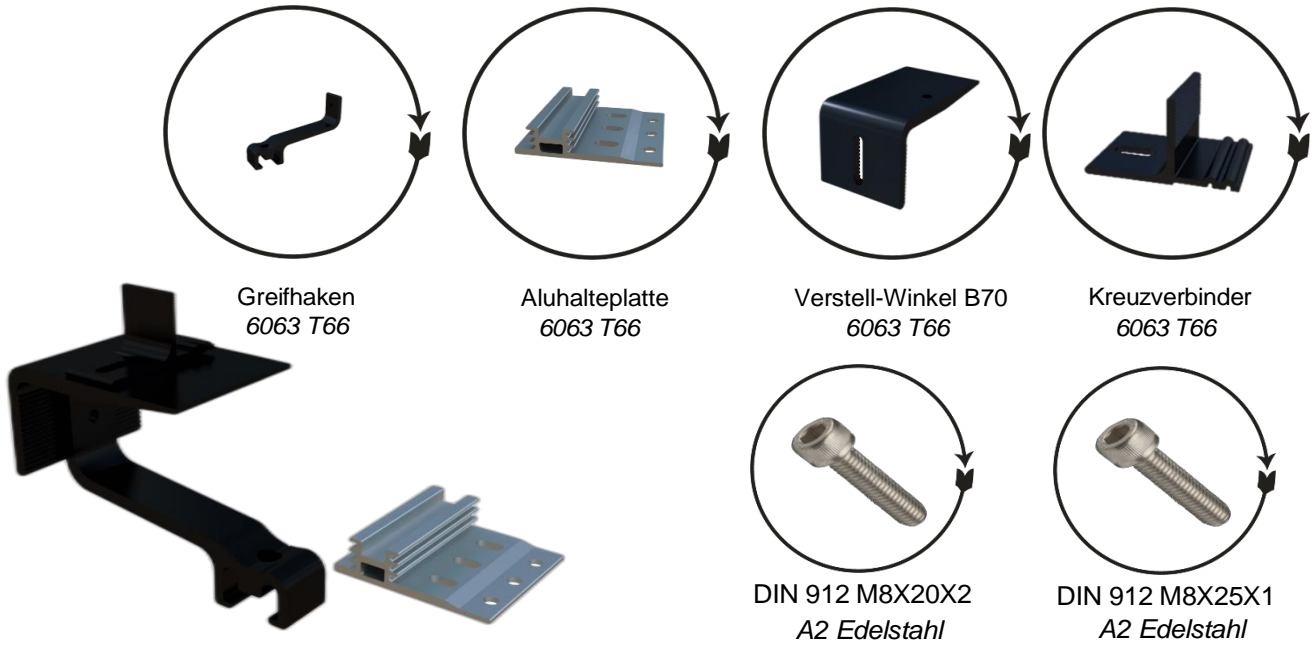

Art.Nr.	Bezeichnung	Material	Oberfläche	Stück/ Karton	Verpackung LXBXH	gr/ Stück
8113	Halteplatte	EN AW 6063 T66	Schwarz Eloxiert	20	60 X 40 X 10	219,5
8114	Greifhaken	EN AW 6063 T66	Schwarz Eloxiert	20		208,67
811570	Verstell-Winkel B70	EN AW 6063 T66	Schwarz Eloxiert	20		268,21
8256	Kreuzverbinder (M8)	EN AW 6063 T66	Schwarz Eloxiert	20		41,07
10102	Inbusschraube DIN 912 M8X20	A2	Edelstahl	40		14,24
10106	Inbusschraube DIN 912 M8X25	A2	Edelstahl	20		15,97

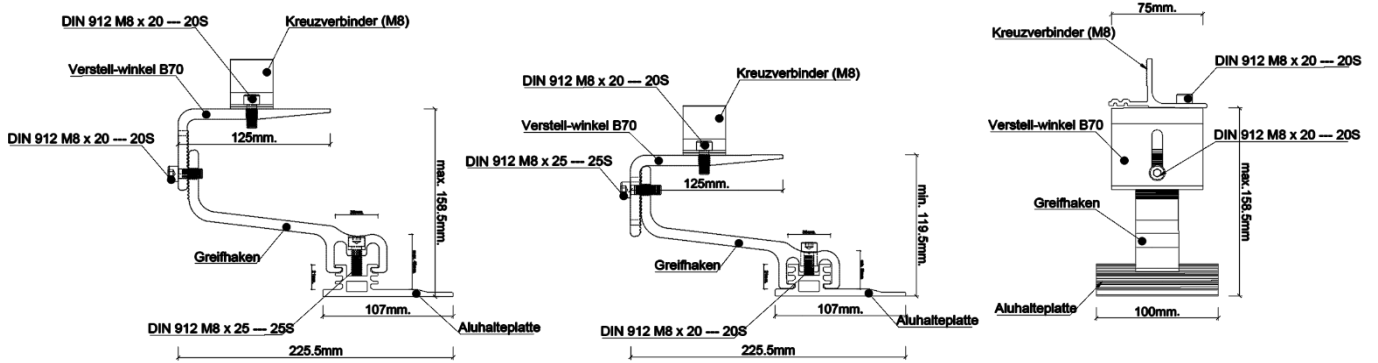

CERTIFICATE OF CONFORMITY OF THE FACTORY PRODUCTION CONTROL  
2674-CPR-233541

In compliance with Regulation (EU) No 305/2011 of the European Parliament and of the Council of 9 March 2011 (the Construction products Regulation od CPR), this certificate applies to the construction products.

CONSTRUCTION PRODUCT(S)

Scope of certificate : Aluminium and aluminium alloys-Structural products for construction Works

EN 150088:2005

under system 2+ are applied that

the factory production control is assessed to be conformity with the applicable requirements.

This certificate was first issued on <20.12.2023> and will remain valid as long as neither the harmonised standard, the construction product, the AVCP methods nor the manufacturing conditions in the plant are modified significantly, unless suspended or withdrawn by FQC Standard Uygunluk Degerlendirme A. Ş. The validity of the document is ensured by annual audits.

- Dimension and Shape Tolerances -Yield Strength -Tensile Strength -Elongation	Product	General Conditions	Specific Conditions		Dimensions	Alloy
			Mechanical Specifications	Tolerance		
	Extrude Profile	EN 755-1	EN 755-2	EN 755-9	Thickness min 0.9 mm. Thickness max. 20.0 mm.	EN AW 6060 EN AW 6063 EN AW 6463



# Technisches Datenblatt

## 231467 Dachhaken Easy SRVH2 Blank Set

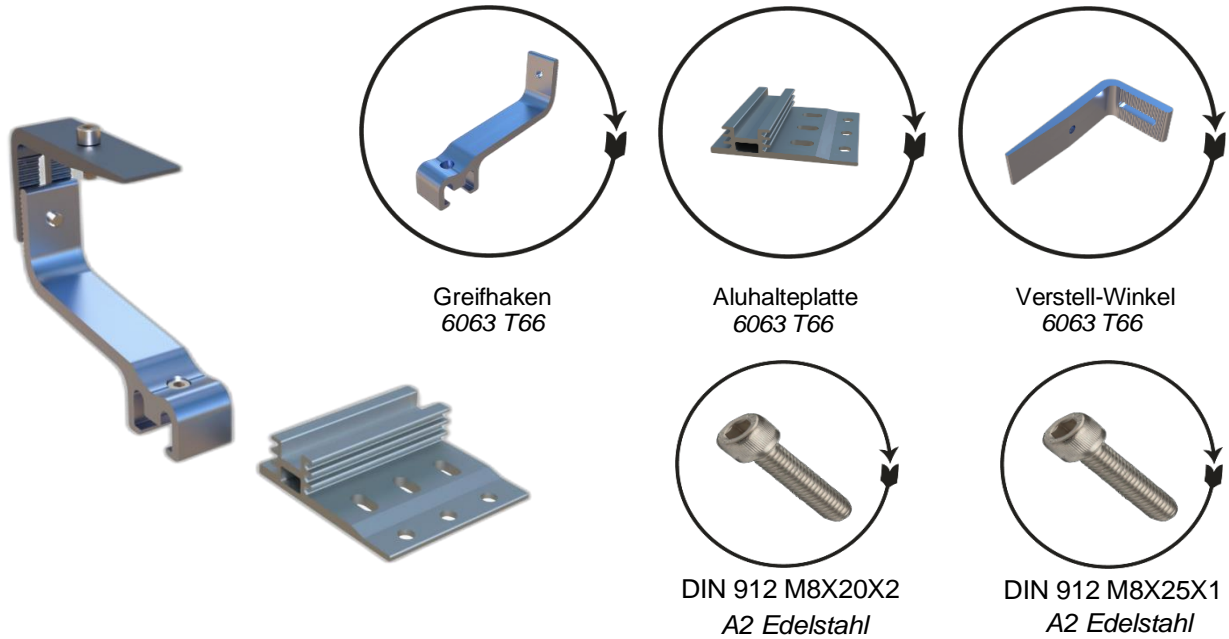

Art.Nr.	Bezeichnung	Material	Oberfläche	Stück/ Karton	Verpackung LXBXH	gr/ Stück
8113	Halteplatte	EN AW 6063 T66	Blank	20	60 X 40 X 10	219,5
8114	Greifhaken	EN AW 6063 T66	Blank	20		208,67
8115	Verstell-Winkel	EN AW 6063 T66	Blank	20		121,09
10102	Inbusschraube DIN 912 M8X20	A2	Edelstahl	40		14,24
10106	Inbusschraube DIN 912 M8X25	A2	Edelstahl	20		15,97

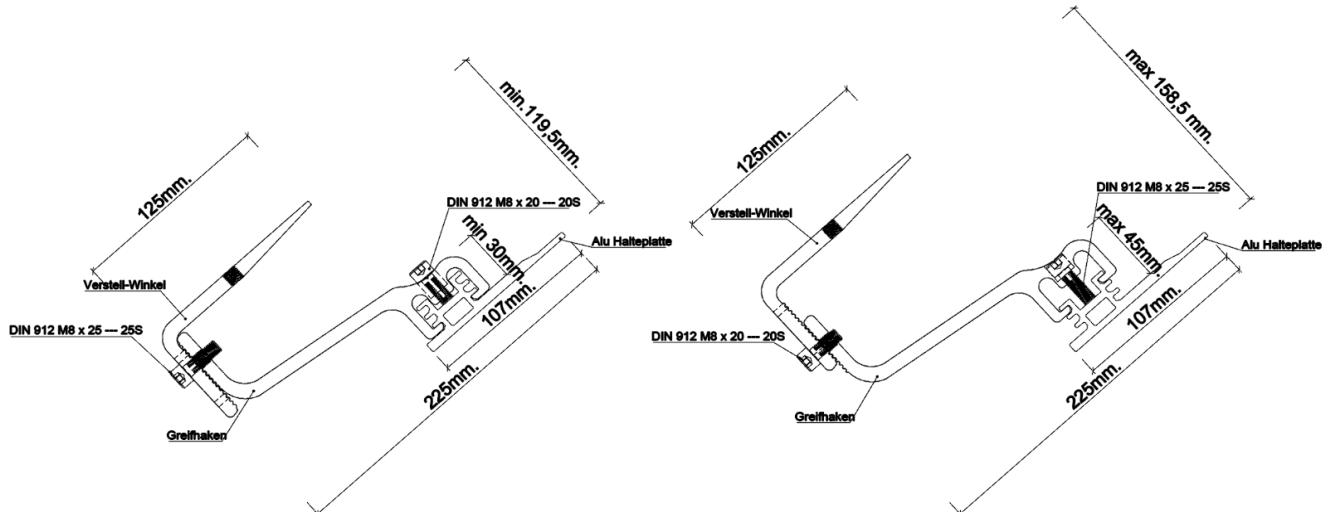

CERTIFICATE OF CONFORMITY OF THE FACTORY PRODUCTION CONTROL  
2674-CPR-233541

In compliance with Regulation (EU) No 305/2011 of the European Parliament and of the Council of 9 March 2011 (the Construction products Regulation od CPR), this certificate applies to the construction products.

CONSTRUCTION PRODUCT(S)

Scope of certificate : Aluminium and aluminium alloys-Structural products for construction Works

EN 150088:2005

under system 2+ are applied that

the factory production control is assessed to be conformity with the applicable requirements.

This certificate was first issued on <20.12.2023> and will remain valid as long as neither the harmonised standard, the construction product, the AVCP methods nor the manufacturing conditions in the plant are modified significantly, unless suspended or withdrawn by FQC Standard Uygunluk Degerlendirme A. Ş. The validity of the document is ensured by annual audits.

- Dimension and Shape Tolerances -Yield Strength -Tensile Strength -Elongation	Product	General Conditions	Specific Conditions		Dimensions	Alloy
			Mechanical Specifications	Tolerance		
	Extrude Profile	EN 755-1	EN 755-2	EN 755-9	Thickness min 0.9 mm. Thickness max. 20.0 mm.	EN AW 6060 EN AW 6063 EN AW 6463



## Profile

# Technisches Datenblatt

## 8100 Montageschiene Blank 4740 ( L=4900 mm )

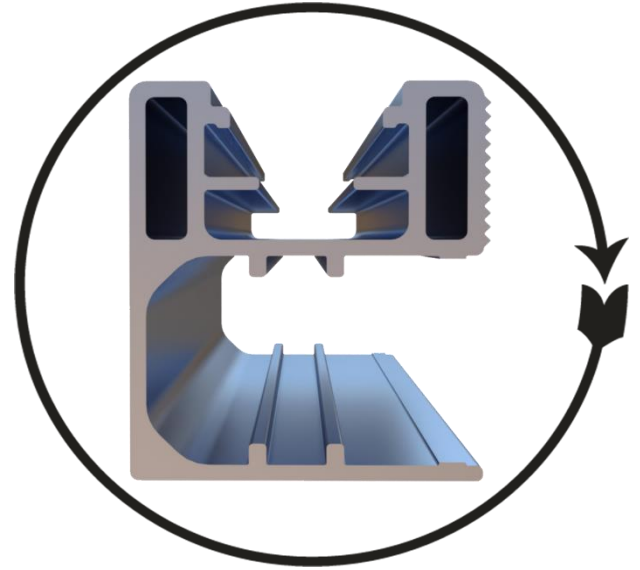
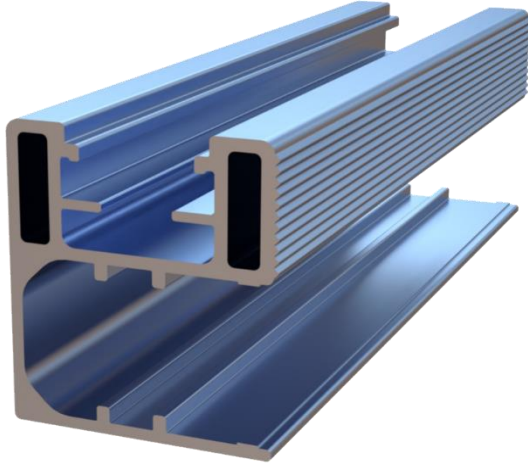

Montageschiene Blank 4740  
6063 T66

Bezeichnung	Material	Oberfläche	Stück/ Karton	Verpackung LXBXH	kg/ Stück
Montageschiene 4740( L=4900 mm )	EN AW 6063 T66	Blank	72	4900 X 550 X 450	5,98

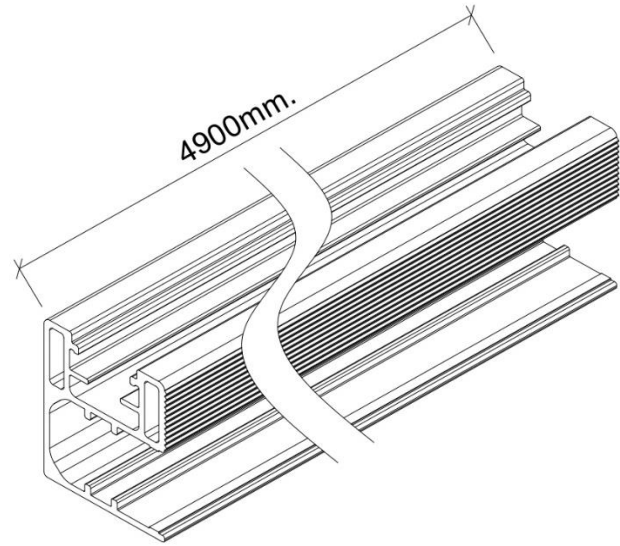
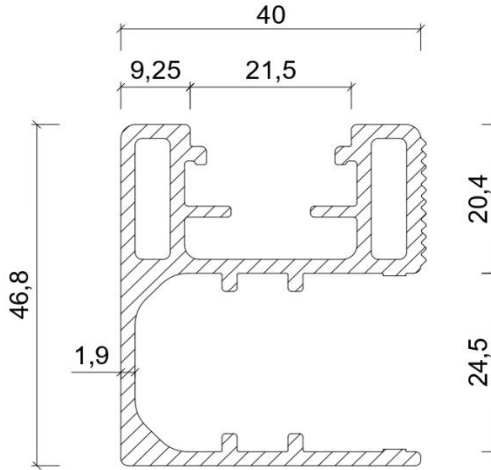

CERTIFIKATE OF CONFORMITY OF THE FACTORY PRODUCTION CONTROL  
2674-CPR-233541

In compliance with Regulation (EU) No 305/2011 of the European Parliament and of the Council of 9 March 2011 (the Construction products Regulation od CPR), this certificate applies to the construction products.

CONSTRUCTION PRODUCT(S)

Scope of certificate : Aluminium and aluminium alloys-Structural products for construction Works

EN 150088:2005

under system 2+ are applied that

the factory production control is assessed to be conformity with the applicable requirements.

This certificate was first issued on <20.12.2023> and will remain valid as long as neither the harmonised standard, the construction product, the AVCP methods nor the manufacturing conditions in the plant are modified significantly, unless suspended or withdrawn by FQC Standard Uygunluk Degerlendirme A. Ş. The validity of the document is ensured by annual audits.

- Dimension and Shape Tolerances -Yield Strength -Tensile Strength -Elongation	Product	General Conditions	Specific Conditions		Dimensions	Alloy
			Mechanical Specifications	Tolerance		
	Extrude Profile	EN 755-1	EN 755-2	EN 755-9	Thickness min 0.9 mm. Thickness max. 20.0 mm.	EN AW 6060 EN AW 6063 EN AW 6463



# Technisches Datenblatt

## 8100/1 Montageschiene Schwarz Eloxiert 4740s ( L=4900 mm)

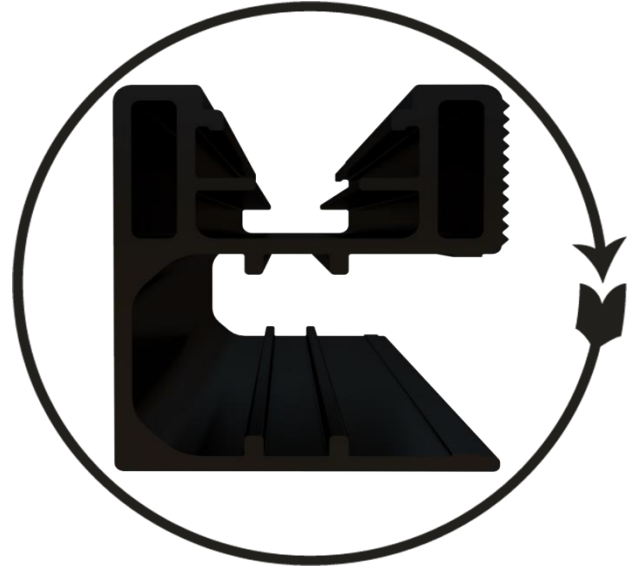
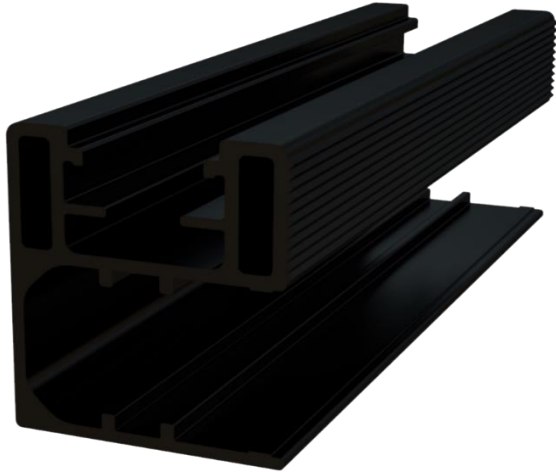

### Montageschiene Schwarz Eloxiert 4740s 6063 T66

Bezeichnung	Material	Oberfläche	Stück/ Karton	Verpackung LXBXH	kg/ Stück
Montageschiene 4740 Montageschiene Schwarz Eloxiert 4740s ( L=4900 mm )	EN AW 6063 T66	Schwarz Eloxiert	72	4900 X 550 X 450	5,98

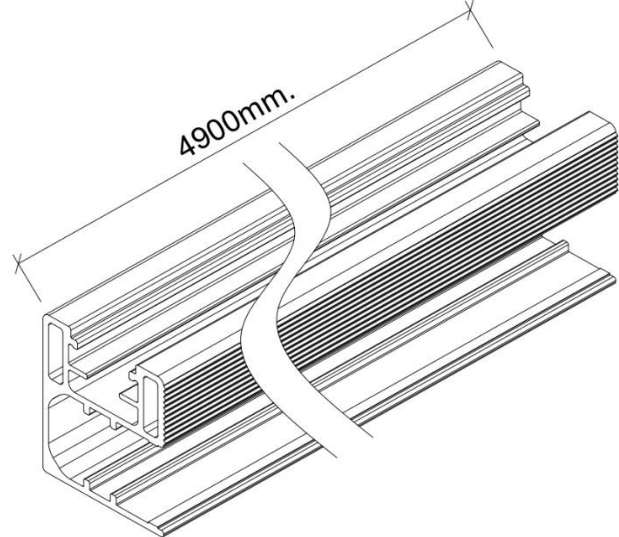
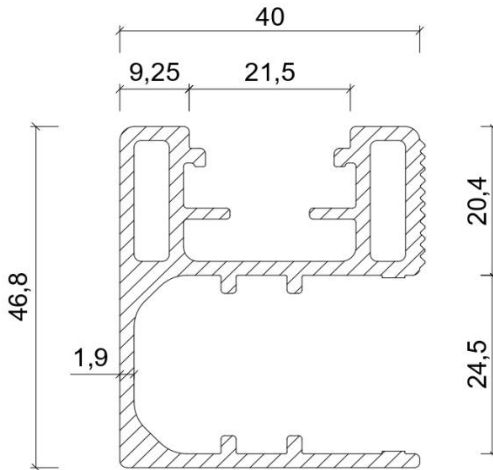

CERTIFIKATE OF CONFORMITY OF THE FACTORY PRODUCTION CONTROL  
2674-CPR-233541

In compliance with Regulation (EU) No 305/2011 of the European Parliament and of the Council of 9 March 2011 (the Construction products Regulation od CPR), this certificate applies to the construction products.

CONSTRUCTION PRODUCT(S)

Scope of certificate : Aluminium and aluminium alloys-Structural products for construction Works

EN 150088:2005

under system 2+ are applied that

the factory production control is assessed to be conformity with the applicable requirements.

This certificate was first issued on <20.12.2023> and will remain valid as long as neither the harmonised standard, the construction product, the AVCP methods nor the manufacturing conditions in the plant are modified significantly, unless suspended or withdrawn by FQC Standard Uygunluk Degerlendirme A. Ş. The validity of the document is ensured by annual audits.

- Dimension and Shape Tolerances -Yield Strength -Tensile Strength -Elongation	Product	General Conditions	Specific Conditions		Dimensions	Alloy
			Mechanical Specifications	Tolerance		
	Extrude Profile	EN 755-1	EN 755-2	EN 755-9	Thickness min 0.9 mm. Thickness max. 20.0 mm.	EN AW 6060 EN AW 6063 EN AW 6463





# Technisches Datenblatt

## 8101 Schienenverbinder Blank ( 200mm )

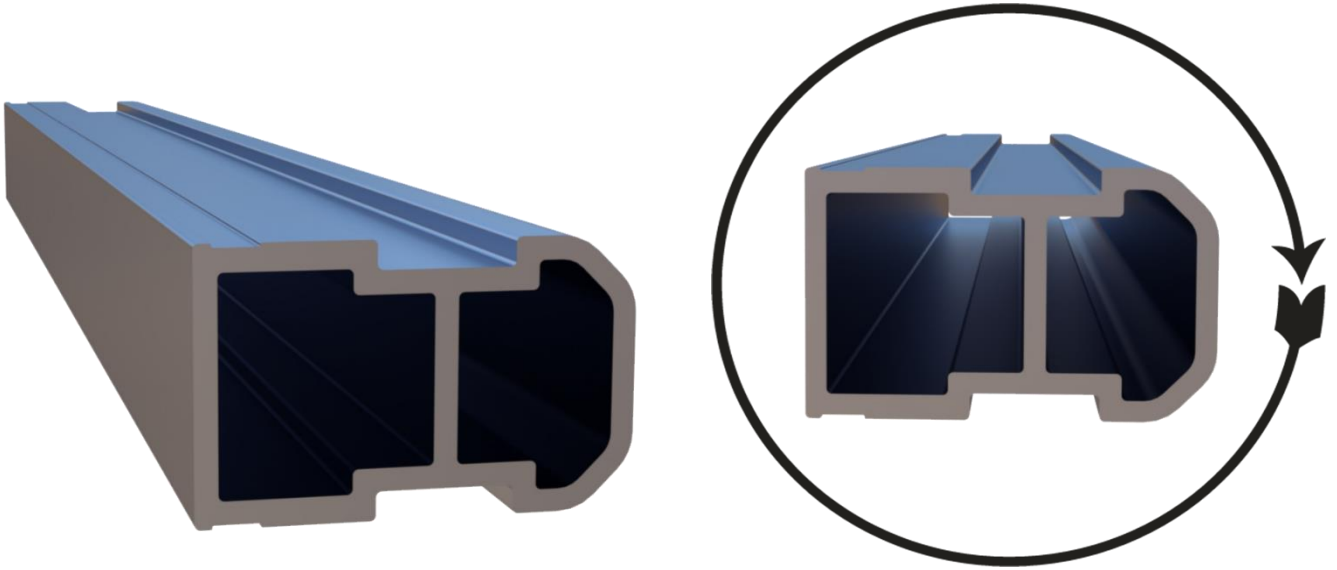

Schienenverbinder Blank  
6063 T66

Bezeichnung	Material	Oberfläche	Stück/ Karton	Verpackung LXBXH	gr/ Stück
Schienenverbinder 200mm.	EN AW 6063 T66	Blank	42	40 X 30 X 10	146,85

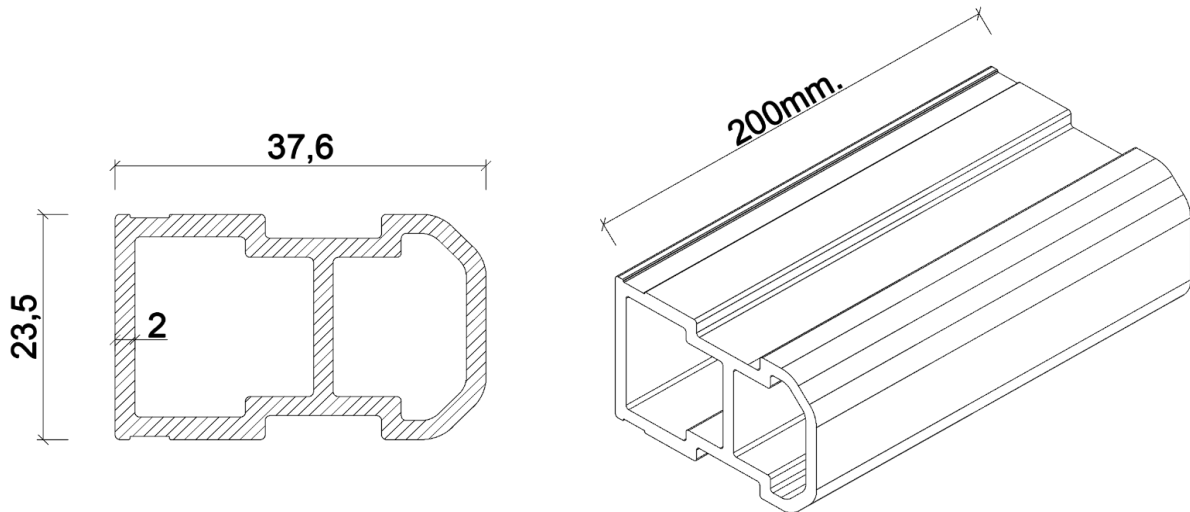

CERTIFIKATE OF CONFORMITY OF THE FACTORY PRODUCTION CONTROL  
2674-CPR-233541

In compliance with Regulation (EU) No 305/2011 of the European Parliament and of the Council of 9 March 2011 (the Construction products Regulation od CPR), this certificate applies to the construction products.

CONSTRUCTION PRODUCT(S)

Scope of certificate : Aluminium and aluminium alloys-Structural products for construction Works

EN 15008:2005

under system 2+ are applied that

the factory production control is assessed to be conformity with the applicable requirements.

This certificate was first issued on <20.12.2023> and will remain valid as long as neither the harmonised standard, the construction product, the AVCP methods nor the manufacturing conditions in the plant are modified significantly, unless suspended or withdrawn by FQC Standard Uygunluk Degerlendirme A. Ş. The validity of the document is ensured by annual audits.

- Dimension and Shape Tolerances -Yield Strength -Tensile Strength -Elongation	Product	General Conditions	Specific Conditions		Dimensions	Alloy
			Mechanical Specifications	Tolerance		
	Extrude Profile	EN 755-1	EN 755-2	EN 755-9	Thickness min 0.9 mm. Thickness max. 20.0 mm.	EN AW 6060 EN AW 6063 EN AW 6463



## 8102 Schienenverbinder Schwarz Eloxiert ( 200 mm )

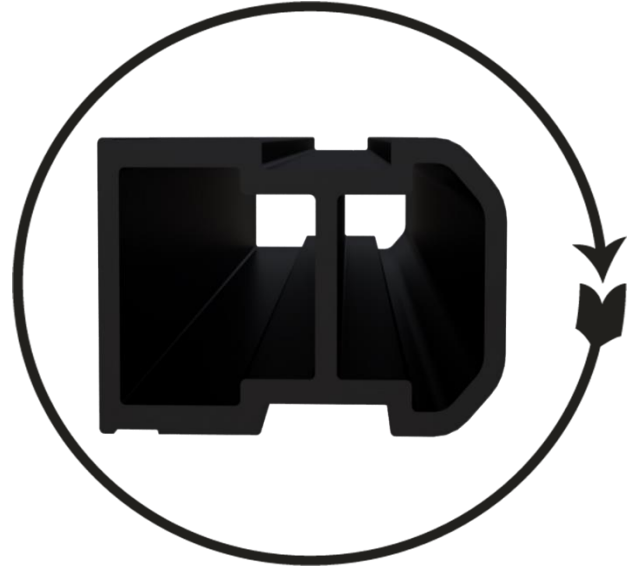
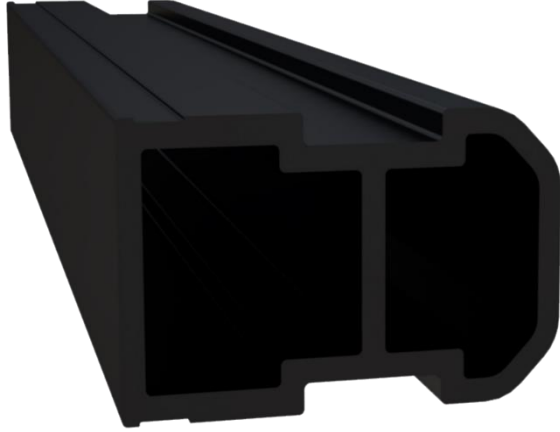

Schienenverbinder  
6063 T66

Bezeichnung	Material	Oberfläche	Stück/ Karton	Verpackung LXBXH	gr/ Stück
Schienenverbinder 200mm.	EN AW 6063 T66	Schwarz Eloxiert	42	40 X 30 X 10	146,85

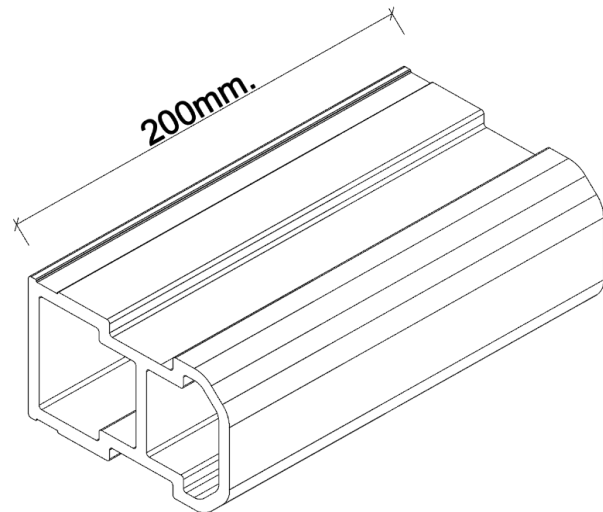
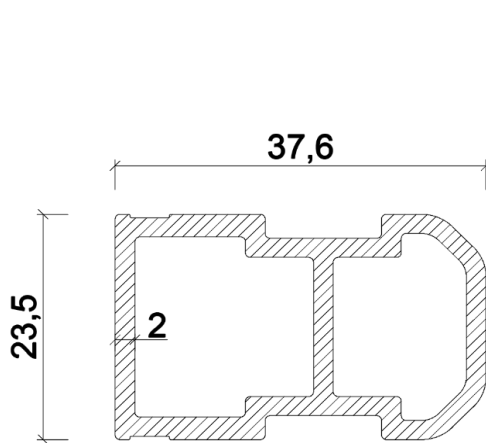

CERTIFIKATE OF CONFORMITY OF THE FACTORY PRODUCTION CONTROL  
2674-CPR-233541

In compliance with Regulation (EU) No 305/2011 of the European Parliament and of the Council of 9 March 2011 (the Construction products Regulation od CPR), this certificate applies to the construction products.

CONSTRUCTION PRODUCT(S)

Scope of certificate : Aluminium and aluminium alloys-Structural products for construction Works

EN 150088:2005

under system 2+ are applied that

the factory production control is assessed to be conformity with the applicable requirements.

This certificate was first issued on <20.12.2023> and will remain valid as long as neither the harmonised standard, the construction product, the AVCP methods nor the manufacturing conditions in the plant are modified significantly, unless suspended or withdrawn by FQC Standard Uygunluk Degerlendirme A. Ş. The validity of the document is ensured by annual audits.

- Dimension and Shape Tolerances -Yield Strength -Tensile Strength -Elongation	Product	General Conductions	Specific Conductions		Dimensions	Alloy
			Mechanical Specifications	Tolarance		
	Extrude Profile	EN 755-1	EN 755-2	EN 755-9	Thickness min 0.9 mm. Thickness max. 20.0 mm.	EN AW 6060 EN AW 6063 EN AW 6463



# Technisches Datenblatt

## 8105 Aluhalteplatte 4900 mm ohne Bohrung

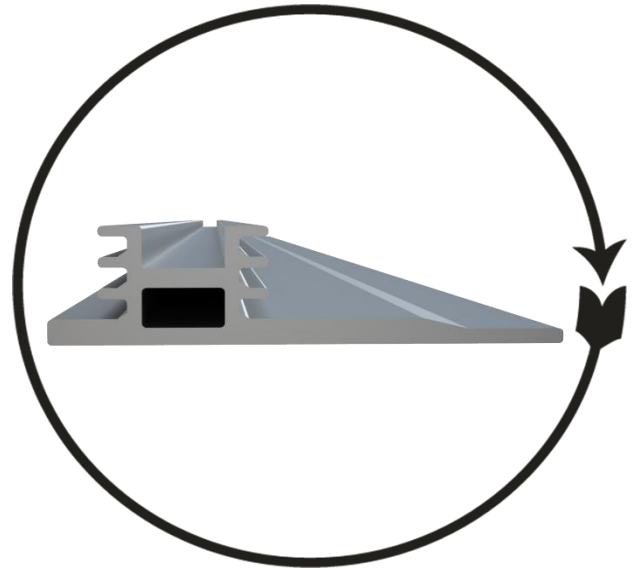

Aluhalteplatte 4900 mm ohne Bohrung  
6063 T66

Bezeichnung	Material	Oberfläche	Stück/ Karton	Verpackung LXBXH	kg/ Stück
Aluhalteplatte 4900 mm ohne Bohrung	EN AW 6063 T66	Blank	72	4900 X 550 X 250	11,17

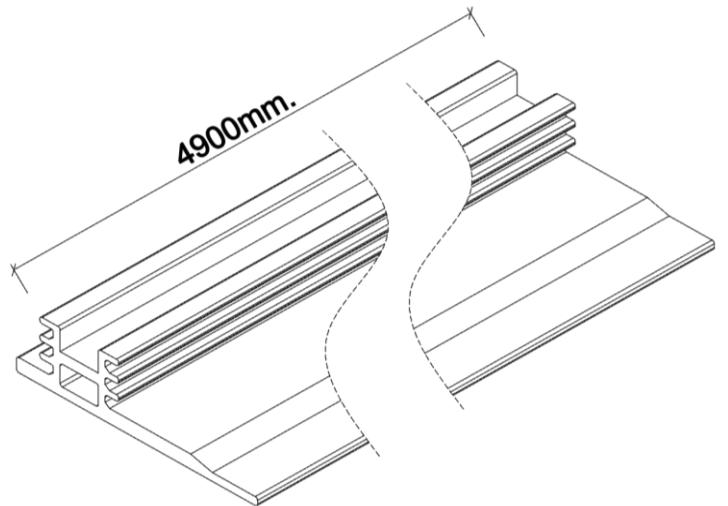
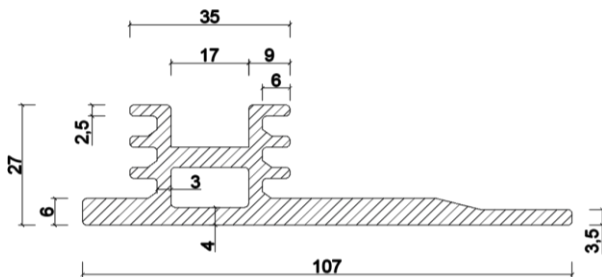

CERTIFIKATE OF CONFORMITY OF THE FACTORY PRODUCTION CONTROL  
2674-CPR-233541

In compliance with Regulation (EU) No 305/2011 of the European Parliament and of the Council of 9 March 2011 (the Construction products Regulation od CPR), this certificate applies to the construction products.

CONSTRUCTION PRODUCT(S)

Scope of certificate : Aluminium and aluminium alloys-Structural products for construction Works

EN 150088:2005

under system 2+ are applied that

the factory production control is assessed to be conformity with the applicable requirements.

This certificate was first issued on <20.12.2023> and will remain valid as long as neither the harmonised standard, the construction product, the AVCP methods nor the manufacturing conditions in the plant are modified significantly, unless suspended or withdrawn by FQC Standard Uygunluk Degerlendirme A. Ş. The validity of the document is ensured by annual audits.

- Dimension and Shape Tolerances -Yield Strength -Tensile Strength -Elongation	Product	General Conditions	Specific Conditions		Dimensions	Alloy
			Mechanical Specifications	Tolerance		
	Extrude Profile	EN 755-1	EN 755-2	EN 755-9	Thickness min 0.9 mm. Thickness max. 20.0 mm.	EN AW 6060 EN AW 6063 EN AW 6463



## 8600/1 Kurzschiene ohne Bohrung und EPDM (L= 5000 mm)

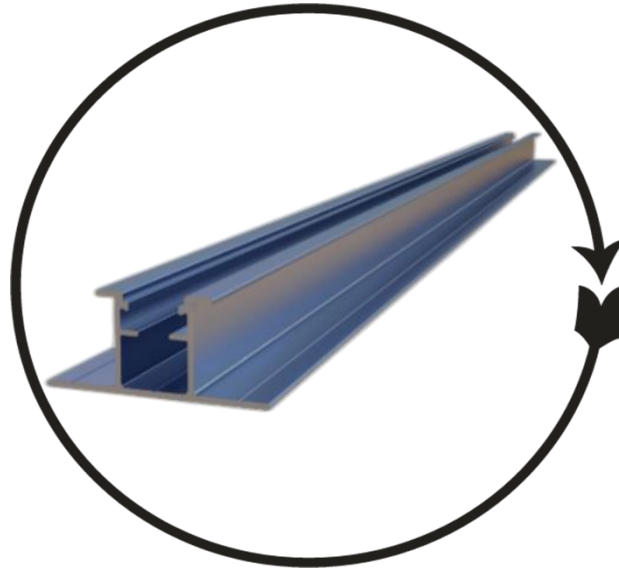

Kurzschiene ohne Bohrung und EPDM  
6063 T66

Bezeichnung	Material	Oberfläche	Stück/ Karton	Verpackung LXBXH	kg/ Stück
Kurzschiene ohne Bohrung und EPDM (L= 5000 mm)	EN AW 6063 T66	Blank	35	5000 X 300 X 175	4,45

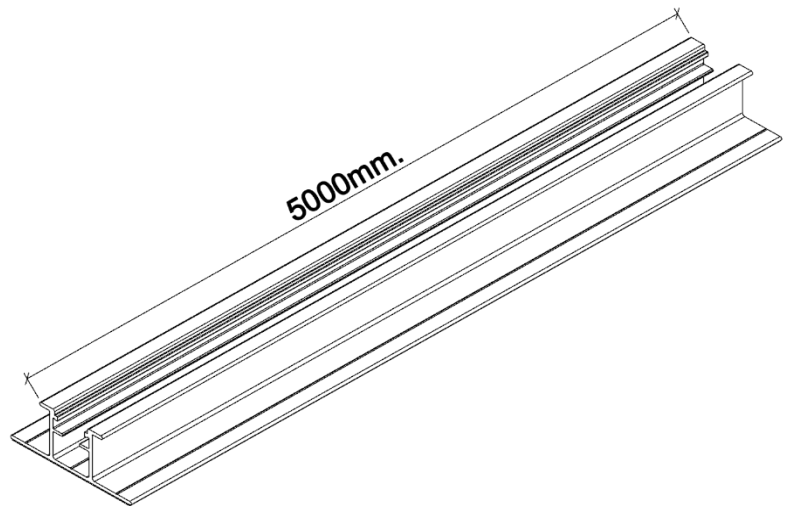
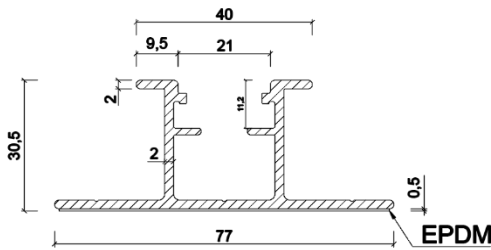

CERTIFIKATE OF CONFORMITY OF THE FACTORY PRODUCTION CONTROL  
2674-CPR-233541

In compliance with Regulation (EU) No 305/2011 of the European Parliament and of the Council of 9 March 2011 (the Construction products Regulation od CPR), this certificate applies to the construction products.

CONSTRUCTION PRODUCT(S)

Scope of certificate : Aluminium and aluminium alloys-Structural products for construction Works

EN 150088:2005

under system 2+ are applied that

the factory production control is assessed to be conformity with the applicable requirements.

This certificate was first issued on <20.12.2023> and will remain valid as long as neither the harmonised standard, the construction product, the AVCP methods nor the manufacturing conditions in the plant are modified significantly, unless suspended or withdrawn by FQC Standard Uygunluk Degerlendirme A. Ş. The validity of the document is ensured by annual audits.

- Dimension and Shape Tolerances -Yield Strength -Tensile Strength -Elongation	Product	General Conditions	Specific Conditions		Dimensions	Alloy
			Mechanical Specifications	Tolerance		
	Extrude Profile	EN 755-1	EN 755-2	EN 755-9	Thickness min 0.9 mm. Thickness max. 20.0 mm.	EN AW 6060 EN AW 6063 EN AW 6463



# Technisches Datenblatt

## 8107 Montageschiene Blank 4027 ( L=4900 mm )

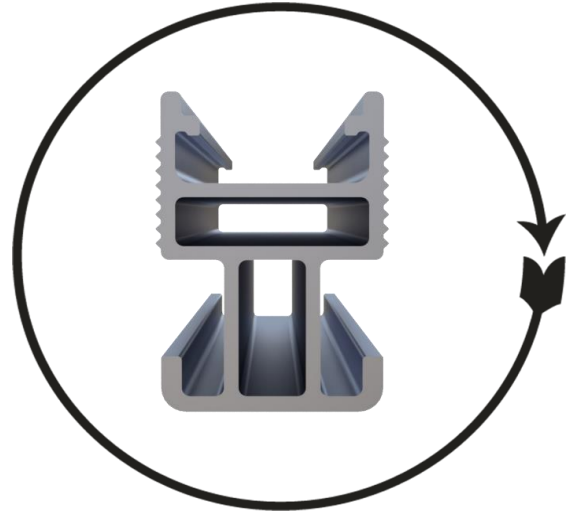
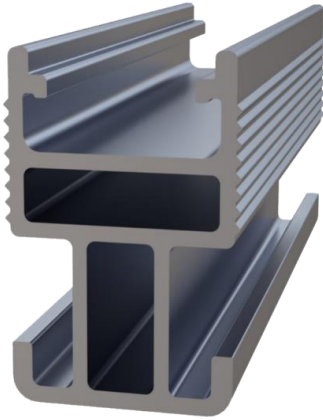

Montageschiene Blank 4027  
6063 T66

Bezeichnung	Material	Oberfläche	Stück/ Karton	Verpackung LXBXH	kg/ Stück
Montageschiene Blank 4027 ( L=4900 mm )	EN AW 6063 T66	Blank	165	4900 X 550 X 450	4,22

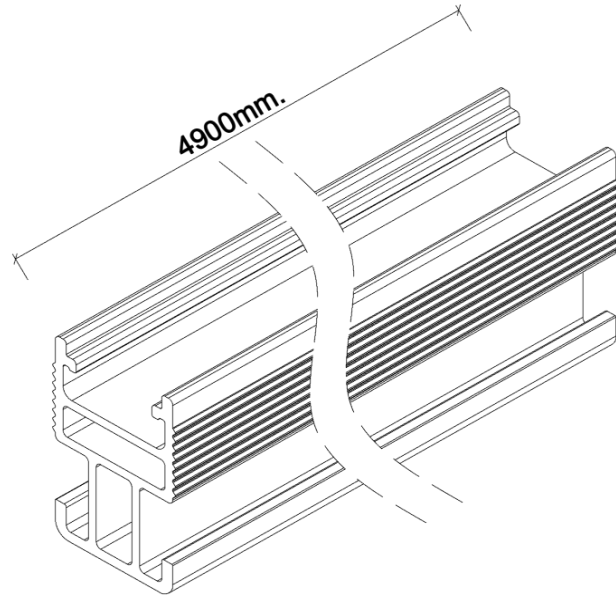
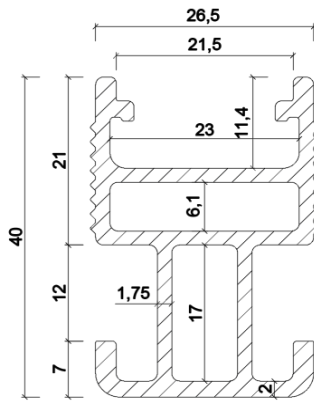

CERTIFIKATE OF CONFORMITY OF THE FACTORY PRODUCTION CONTROL  
2674-CPR-233541

In compliance with Regulation (EU) No 305/2011 of the European Parliament and of the Council of 9 March 2011 (the Construction products Regulation od CPR), this certificate applies to the construction products.

CONSTRUCTION PRODUCT(S)

Scope of certificate : Aluminium and aluminium alloys-Structural products for construction Works

EN 150088:2005

under system 2+ are applied that

the factory production control is assessed to be conformity with the applicable requirements.

This certificate was first issued on <20.12.2023> and will remain valid as long as neither the harmonised standard, the construction product, the AVCP methods nor the manufacturing conditions in the plant are modified significantly, unless suspended or withdrawn by FQC Standard Uygunluk Degerlendirme A. Ş. The validity of the document is ensured by annual audits.

- Dimension and Shape Tolerances -Yield Strength -Tensile Strength -Elongation	Product	General Conductions	Specific Conductions		Dimensions	Alloy
			Mechanical Specifications	Tolarance		
	Extrude Profile	EN 755-1	EN 755-2	EN 755-9	Thickness min 0.9 mm. Thickness max. 20.0 mm.	EN AW 6060 EN AW 6063 EN AW 6463



# Technisches Datenblatt

## 8107/1 Montageschiene 4027 Schwarz Eloxiert

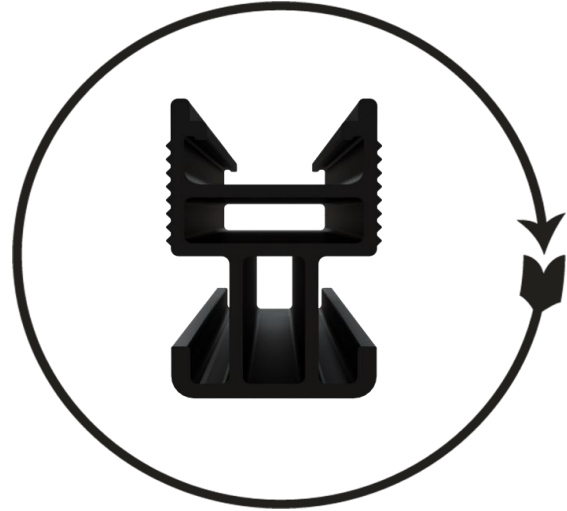

Montageschiene 4027 Schwarz Eloxiert  
6063 T66

Bezeichnung	Material	Oberfläche	Stück/ Karton	Verpackung LXBXH	kg/ Stück
Montageschiene 4027 ( L=4900 mm )	EN AW 6063 T66	Schwarz Eloxiert	165	4900 X 550 X 450	4,22

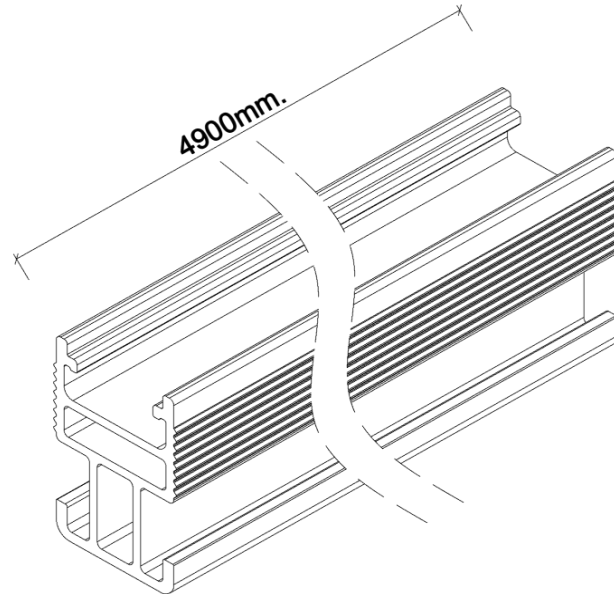
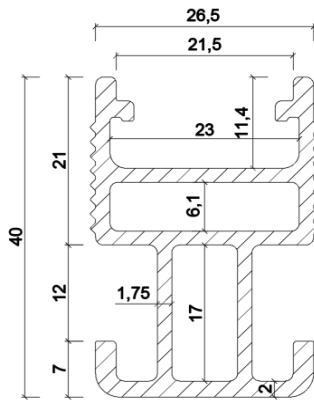

CERTIFIKATE OF CONFORMITY OF THE FACTORY PRODUCTION CONTROL  
2674-CPR-233541

In compliance with Regulation (EU) No 305/2011 of the European Parliament and of the Council of 9 March 2011 (the Construction products Regulation od CPR), this certificate applies to the construction products.

CONSTRUCTION PRODUCT(S)

Scope of certificate : Aluminium and aluminium alloys-Structural products for construction Works

EN 150088:2005

under system 2+ are applied that

the factory production control is assessed to be conformity with the applicable requirements.

This certificate was first issued on <20.12.2023> and will remain valid as long as neither the harmonised standard, the construction product, the AVCP methods nor the manufacturing conditions in the plant are modified significantly, unless suspended or withdrawn by FQC Standard Uygunluk Degerlendirme A. Ş. The validity of the document is ensured by annual audits.

- Dimension and Shape -Tolerances -Yield Strength -Tensile Strength -Elongation	Product	General Conditions	Specific Conditions		Dimensions	Alloy
			Mechanical Specifications	Tolerance		
	Extrude Profile	EN 755-1	EN 755-2	EN 755-9	Thickness min 0.9 mm. Thickness max. 20.0 mm.	EN AW 6060 EN AW 6063 EN AW 6463



# Technisches Datenblatt

## 8108 Montageschiene Blank 5027 ( L=4900 mm )

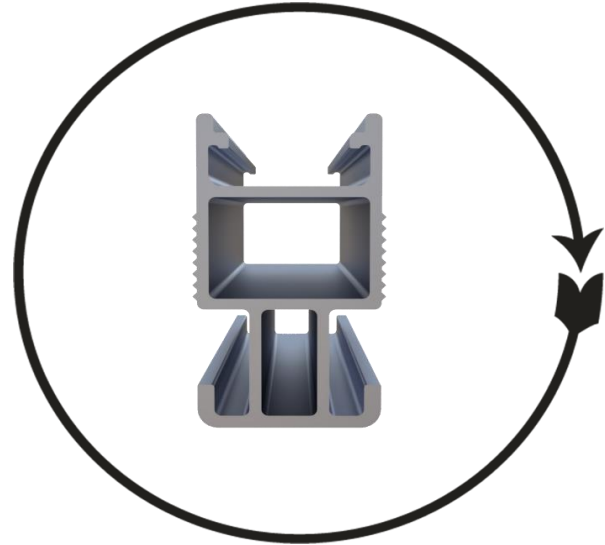
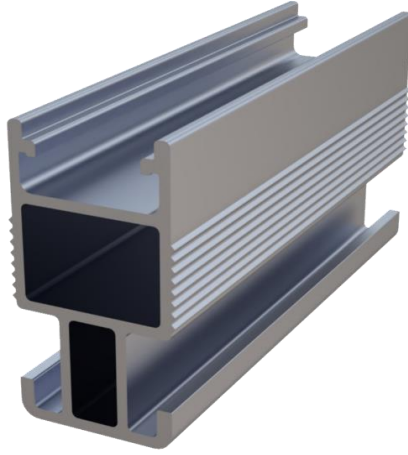

Montageschiene Blank 5027  
6063 T66

Bezeichnung	Material	Oberfläche	Stück/ Karton	Verpackung LXBXH	kg/ Stück
Montageschiene Blank 5027 ( L=4900 mm )	EN AW 6063 T66	Blank	135	4900 X 550 X 450	4,69

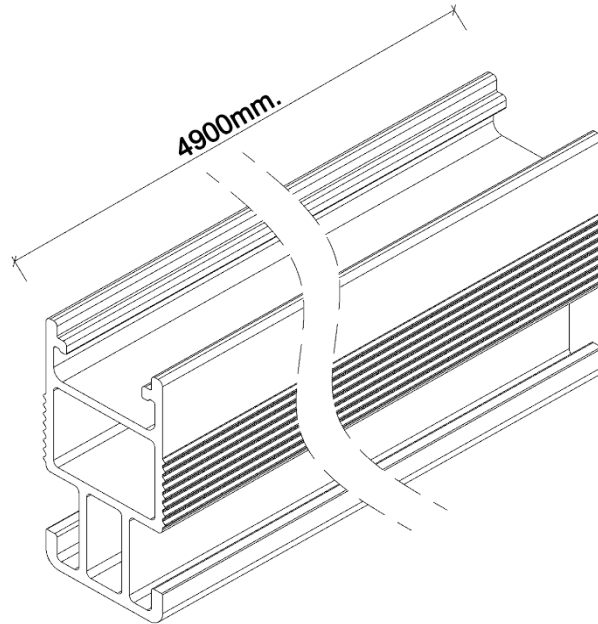
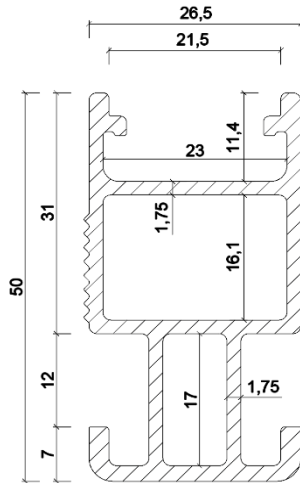

CERTIFIKATE OF CONFORMITY OF THE FACTORY PRODUCTION CONTROL  
2674-CPR-233541

In compliance with Regulation (EU) No 305/2011 of the European Parliament and of the Council of 9 March 2011 (the Construction products Regulation od CPR), this certificate applies to the construction products.

CONSTRUCTION PRODUCT(S)

Scope of certificate : Aluminium and aluminium alloys-Structural products for construction Works

EN 150088:2005

under system 2+ are applied that

the factory production control is assessed to be conformity with the applicable requirements.

This certificate was first issued on <20.12.2023> and will remain valid as long as neither the harmonised standard, the construction product, the AVCP methods nor the manufacturing conditions in the plant are modified significantly, unless suspended or withdrawn by FQC Standard Uygunluk Degerlendirme A. Ş. The validity of the document is ensured by annual audits.

- Dimension and Shape Tolerances -Yield Strength -Tensile Strength -Elongation	Product	General Conditions	Specific Conditions		Dimensions	Alloy
			Mechanical Specifications	Tolerance		
	Extrude Profile	EN 755-1	EN 755-2	EN 755-9	Thickness min 0.9 mm. Thickness max. 20.0 mm.	EN AW 6060 EN AW 6063 EN AW 6463



## Technisches Datenblatt

### 8108/1 Montageschiene Schwarz Eloxiert 5027 ( L=4900 mm )

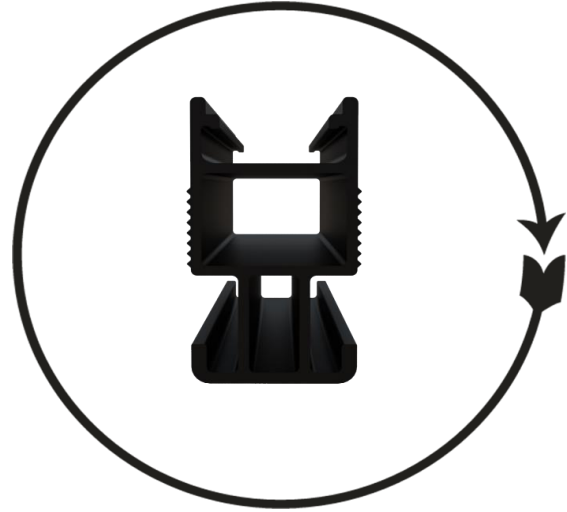

Montageschiene Schwarz Eloxiert 5027  
6063 T66

Bezeichnung	Material	Oberfläche	Stück/ Karton	Verpackung LXBXH	kg/ Stück
Montageschiene Schwarz Eloxiert 5027 ( L=4900 mm )	EN AW 6063 T66	Schwarz Eloxiert	135	4900 X 550 X 450	4,69

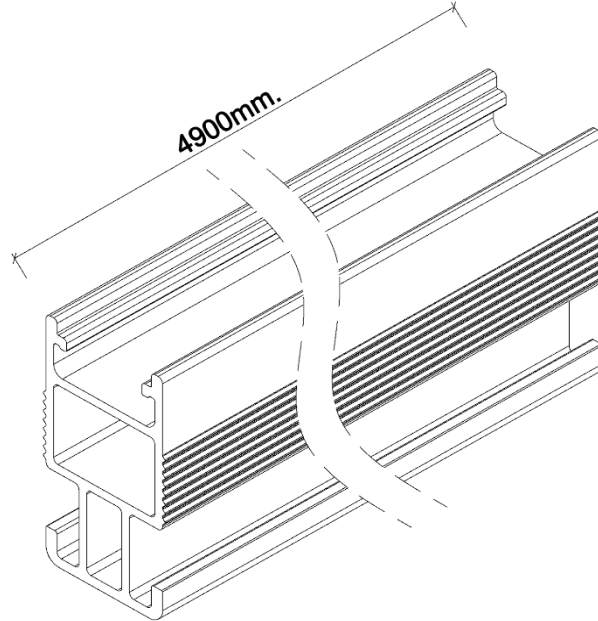
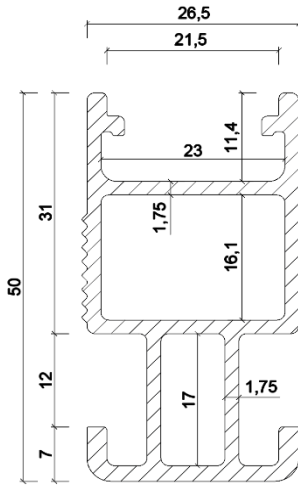

CERTIFIKATE OF CONFORMITY OF THE FACTORY PRODUCTION CONTROL  
2674-CPR-233541

In compliance with Regulation (EU) No 305/2011 of the European Parliament and of the Council of 9 March 2011 (the Construction products Regulation od CPR), this certificate applies to the construction products.

CONSTRUCTION PRODUCT(S)

Scope of certificate : Aluminium and aluminium alloys-Structural products for construction Works

EN 150088:2005

under system 2+ are applied that

the factory production control is assessed to be conformity with the applicable requirements.

This certificate was first issued on <20.12.2023> and will remain valid as long as neither the harmonised standard, the construction product, the AVCP methods nor the manufacturing conditions in the plant are modified significantly, unless suspended or withdrawn by FQC Standard Uygunluk Degerlendirme A. Ş. The validity of the document is ensured by annual audits.

- Dimension and Shape Tolerances -Yield Strength -Tensile Strength -Elongation	Product	General Conditions	Specific Conditions		Dimensions	Alloy
			Mechanical Specifications	Tolerance		
	Extrude Profile	EN 755-1	EN 755-2	EN 755-9	Thickness min 0.9 mm. Thickness max. 20.0 mm.	EN AW 6060 EN AW 6063 EN AW 6463





## **Mittel und Endklemmen**

# Technisches Datenblatt

## 231452 Endklemme Schwarz Eloxiert 35 mm Set



Endklemme Rahmenhöhe 35 mm  
6063 T66

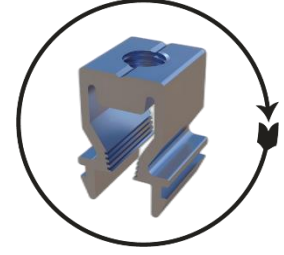

Spreizklemme  
6063 T66



Inbusschraube DIN 7380 M8X40  
A2 Edelstahl

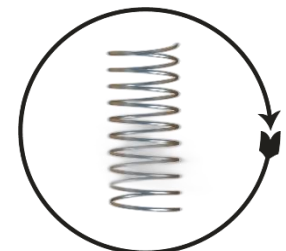

Feder A2 M8 20mm

Art.Nr.	Bezeichnung	Material	Oberfläche	Stück/ Karton	Verpackung LXBXH	gr/ Stück
8251	Endklemme Rahmenhöhe 35 mm	EN AW 6063 T66	Schwarz Eloxiert	100	40 X 30 X 10	23,86
9513	Spreizklemme	EN AW 6063 T66	Blank	100		11,07
10190	Feder A2 M8 20mm	A2	Edelstahl	100		0,39
10105	Inbusschraube DIN 7380 M8X40	A2	Edelstahl	100		17,15

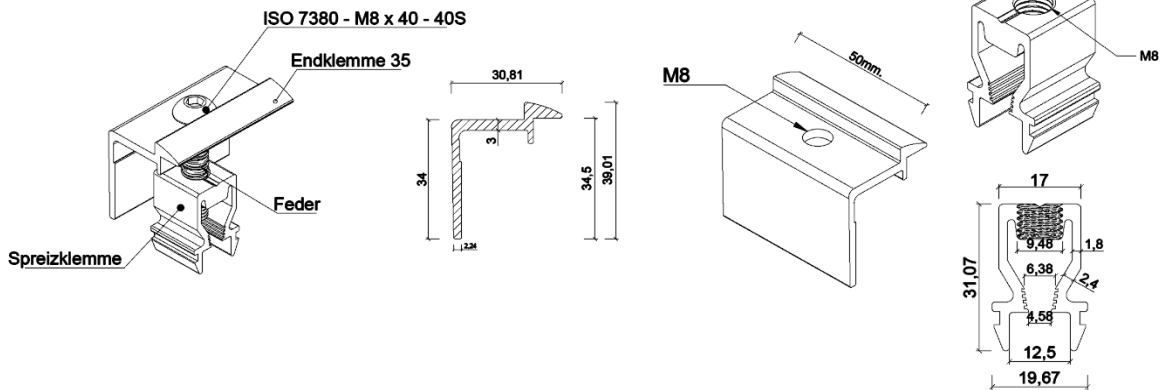

CERTIFIKATE OF CONFORMITY OF THE FACTORY PRODUCTION CONTROL  
2674-CPR-233541

In compliance with Regulation (EU) No 305/2011 of the European Parliament and of the Council of 9 March 2011 (the Construction products Regulation od CPR), this certificate applies to the construction products.

CONSTRUCTION PRODUCT(S)

Scope of certificate : Aluminium and aluminium alloys-Structural products for construction Works

EN 150088:2005

under system 2+ are applied that

the factory production control is assessed to be conformity with the applicable requirements.

This certificate was first issued on <20.12.2023> and will remain valid as long as neither the harmonised standard, the construction product, the AVCP methods nor the manufacturing conditions in the plant are modified significantly, unless suspended or withdrawn by FQC Standard Uygunluk Degerlendirme A. Ş. The validity of the document is ensured by annual audits.

- Dimension and Shape Tolerances -Yield Strength -Tensile Strength -Elongation	Product	General Conditions	Specific Conditions		Dimensions	Alloy
			Mechanical Specifications	Tolerance		
	Extrude Profile	EN 755-1	EN 755-2	EN 755-9	Thickness min 0.9 mm. Thickness max. 20.0 mm.	EN AW 6060 EN AW 6063 EN AW 6463



# Technisches Datenblatt

## 231452P Endklemme Schwarz Eloxiert mit Erdungspin 35mm Set



Endklemme Rahmenhöhe 35 mm  
6063 T66

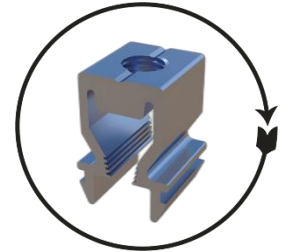

Spreizklemme  
6063 T66



Inbusschraube DIN 7380 M8X40  
A2 Edelstahl

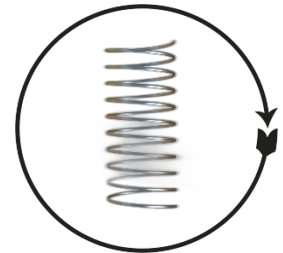

Feder A2 M8 20mm

Art.Nr.	Bezeichnung	Material	Oberfläche	Stück/ Karton	Verpackung LXBXH	gr/ Stück
8251-P	Endklemme Rahmenhöhe 35 mm	EN AW 6063 T66	Schwarz Eloxiert	100	40 X 30 X 10	23,86
9513	Spreizklemme	EN AW 6063 T66	Blank	100		11,07
10190	Feder A2 M8 20mm	A2	Edelstahl	100		0,39
10105	Inbusschraube DIN 7380 M8X40	A2	Edelstahl	100		17,15

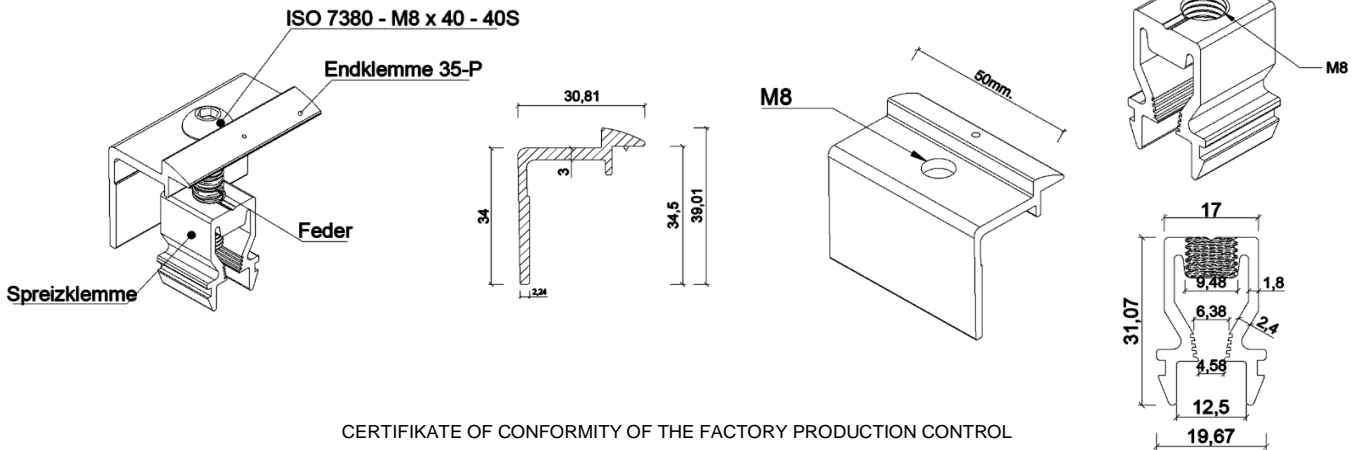

CERTIFIKATE OF CONFORMITY OF THE FACTORY PRODUCTION CONTROL  
2674-CPR-233541

In compliance with Regulation (EU) No 305/2011 of the European Parliament and of the Council of 9 March 2011 (the Construction products Regulation od CPR), this certificate applies to the construction products.

CONSTRUCTION PRODUCT(S)

Scope of certificate : Aluminium and aluminium alloys-Structural products for construction Works

EN 15008:2005

under system 2+ are applied that

the factory production control is assessed to be conformity with the applicable requirements.

This certificate was first issued on <20.12.2023> and will remain valid as long as neither the harmonised standard, the construction product, the AVCP methods nor the manufacturing conditions in the plant are modified significantly, unless suspended or withdrawn by FQC Standard Uygunluk Degerlendirme A. Ş. The validity of the document is ensured by annual audits.

- Dimension and Shape Tolerances -Yield Strength -Tensile Strength -Elongation	Product	General Conductions	Specific Conductions		Dimensions	Alloy
			Mechanical Specifinations	Tolarance		
	Extrude Profile	EN 755-1	EN 755-2	EN 755-9	Thickness min 0.9 mm. Thickness max. 20.0 mm.	EN AW 6060 EN AW 6063 EN AW 6463



# Technisches Datenblatt

## 231453 Endklemme Blank 35 mm Set

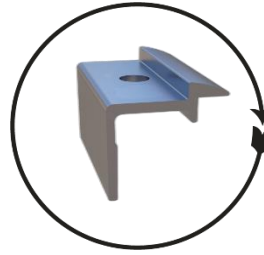

Endklemme Rahmenhöhe 35 mm  
6063 T66

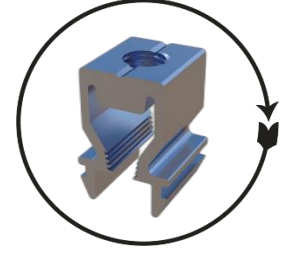

Spreizklemme  
6063 T66



Inbusschraube DIN 7380 M8X40  
A2 Edelstahl

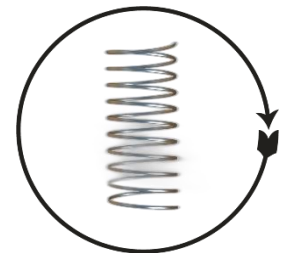

Feder A2 M8 20mm  
A2 Edelstahl

Art.Nr.	Bezeichnung	Material	Oberfläche	Stück/ Karton	Verpackung LXBXH	gr/ Stück
8252	Endklemme Rahmenhöhe 35 mm	EN AW 6063 T66	Blank	100	40 X 30 X 10	23,86
9513	Spreizklemme	EN AW 6063 T66	Blank	100		11,07
10190	Feder A2 M8 20mm	A2	Edelstahl	100		0,39
10105	Inbusschraube DIN 7380 M8X40	A2	Edelstahl	100		17,15

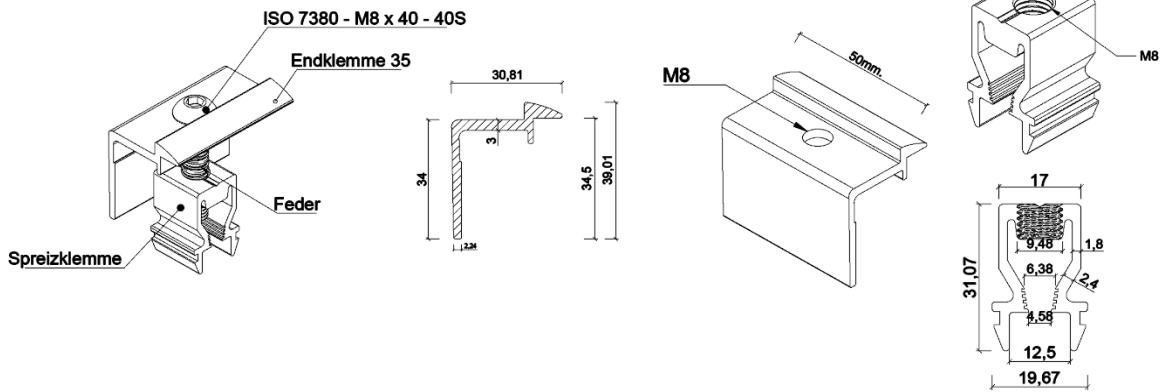

CERTIFIKATE OF CONFORMITY OF THE FACTORY PRODUCTION CONTROL  
2674-CPR-233541

In compliance with Regulation (EU) No 305/2011 of the European Parliament and of the Council of 9 March 2011 (the Construction products Regulation od CPR), this certificate applies to the construction products.

CONSTRUCTION PRODUCT(S)

Scope of certificate : Aluminium and aluminium alloys-Structural products for construction Works

EN 150088:2005

under system 2+ are applied that

the factory production control is assessed to be conformity with the applicable requirements.

This certificate was first issued on <20.12.2023> and will remain valid as long as neither the harmonised standard, the construction product, the AVCP methods nor the manufacturing conditions in the plant are modified significantly, unless suspended or withdrawn by FQC Standard Uygunluk Degerlendirme A. Ş. The validity of the document is ensured by annual audits.

- Dimension and Shape Tolerances -Yield Strength -Tensile Strength -Elongation	Product	General Conductions	Specific Conductions		Dimensions	Alloy
			Mechanical Specifications	Tolerance		
	Extrude Profile	EN 755-1	EN 755-2	EN 755-9	Thickness min 0.9 mm. Thickness max. 20.0 mm.	EN AW 6060 EN AW 6063 EN AW 6463



# Technisches Datenblatt

## 231453P Endklemme mit Erdungspin 35 mm Set

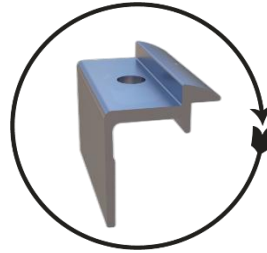

Endklemme Rahmenhöhe 35 mm  
6063 T66

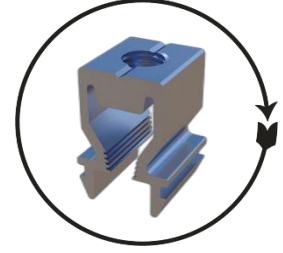

Spreizklemme  
6063 T66



Inbusschraube DIN 7380 M8X40  
A2 Edelstahl

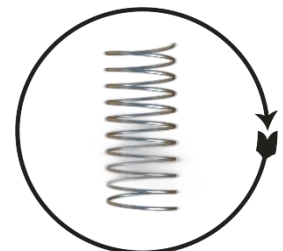

Feder A2 M8 20mm  
A2 Edelstahl

Art.Nr.	Bezeichnung	Material	Oberfläche	Stück/ Karton	Verpackung LXBXH	gr/ Stück
8252-P	Endklemme Rahmenhöhe 35 mm	EN AW 6063 T66	Blank	100	40 X 30 X 10	23,86
9513	Spreizklemme	EN AW 6063 T66	Blank	100		11,07
10190	Feder A2 M8 20mm	A2	Edelstahl	100		0,39
10105	Inbusschraube DIN 7380 M8X40	A2	Edelstahl	100		17,15

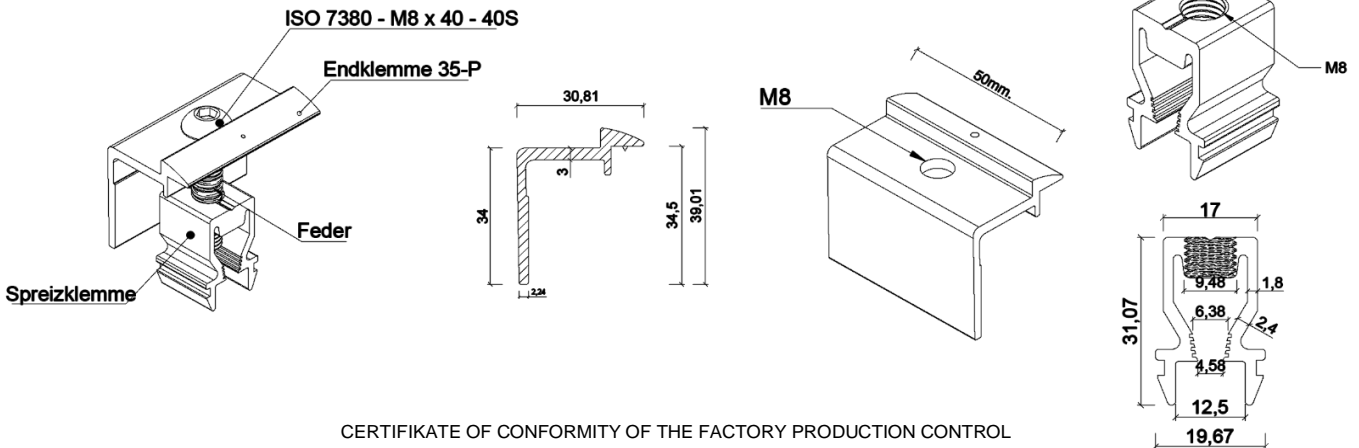

CERTIFIKATE OF CONFORMITY OF THE FACTORY PRODUCTION CONTROL  
2674-CPR-233541

In compliance with Regulation (EU) No 305/2011 of the European Parliament and of the Council of 9 March 2011 (the Construction products Regulation od CPR), this certificate applies to the construction products.

CONSTRUCTION PRODUCT(S)

Scope of certificate : Aluminium and aluminium alloys-Structural products for construction Works

EN 150088:2005

under system 2+ are applied that

the factory production control is assessed to be conformity with the applicable requirements.

This certificate was first issued on <20.12.2023> and will remain valid as long as neither the harmonised standard, the construction product, the AVCP methods nor the manufacturing conditions in the plant are modified significantly, unless suspended or withdrawn by FQC Standard Uygunluk Degerlendirme A. Ş. The validity of the document is ensured by annual audits.

- Dimension and Shape Tolerances -Yield Strength -Tensile Strength -Elongation	Product Extrude Profile	General Conditions EN 755-1	Specific Conditions		Dimensions Thickness min 0.9 mm. Thickness max. 20.0 mm.	Alloy EN AW 6060 EN AW 6063 EN AW 6463
			Mechanical Specifications EN 755-2	Tolerance EN 755-9		



# Technisches Datenblatt

## 231454 Endklemme Blank 30 mm Set

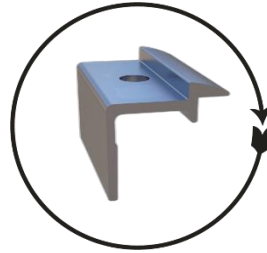

Endklemme Rahmenhöhe 30 mm  
6063 T66

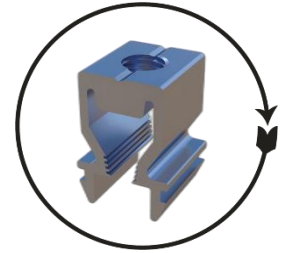

Spreizklemme  
6063 T66



Inbusschraube DIN 7380 M8X40  
A2 Edelstahl

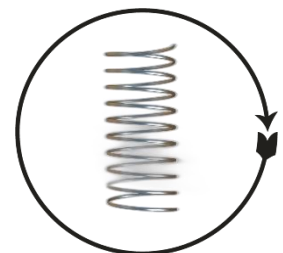

Feder A2 M8 20mm  
A2 Edelstahl

Art.Nr.	Bezeichnung	Material	Oberfläche	Stück/ Karton	Verpackung LXBXH	gr/ Stück
8253	Endklemme Rahmenhöhe 30 mm	EN AW 6063 T66	Blank	100	40 X 30 X 10	22,18
9513	Spreizklemme	EN AW 6063 T66	Blank	100		11,07
10190	Feder A2 M8 20mm	A2	Edelstahl	100		0,39
10105	Inbusschraube DIN 7380 M8X40	A2	Edelstahl	100		17,15

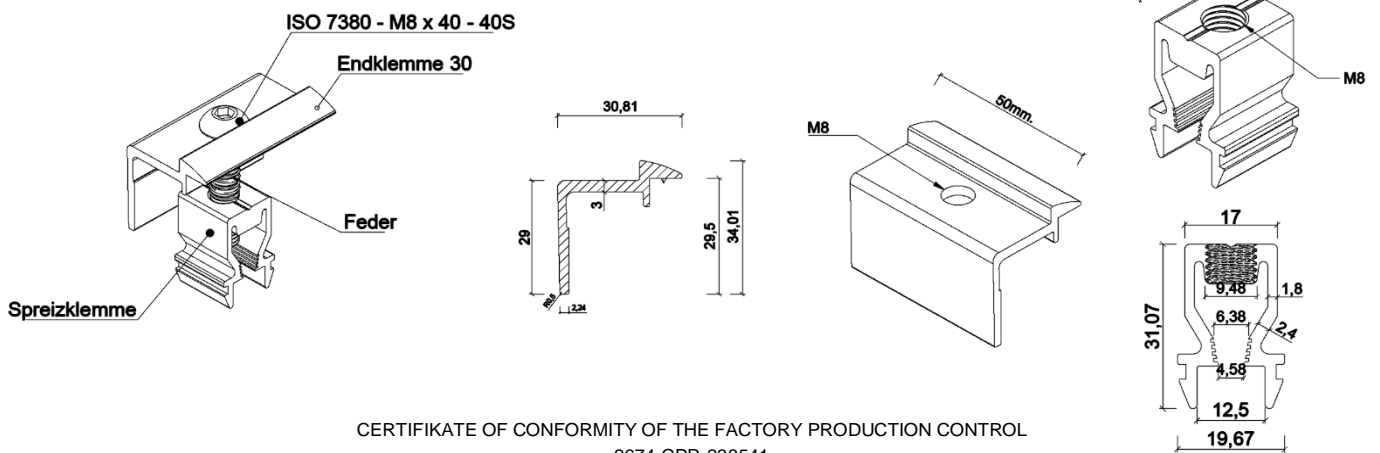

CERTIFIKATE OF CONFORMITY OF THE FACTORY PRODUCTION CONTROL  
2674-CPR-233541

In compliance with Regulation (EU) No 305/2011 of the European Parliament and of the Council of 9 March 2011 (the Construction products Regulation od CPR), this certificate applies to the construction products.

CONSTRUCTION PRODUCT(S)

Scope of certificate : Aluminium and aluminium alloys-Structural products for construction Works

EN 150088:2005

under system 2+ are applied that

the factory production control is assessed to be conformity with the applicable requirements.

This certificate was first issued on <20.12.2023> and will remain valid as long as neither the harmonised standard, the construction product, the AVCP methods nor the manufacturing conditions in the plant are modified significantly, unless suspended or withdrawn by FQC Standard Uygunluk Degerlendirme A. Ş. The validity of the document is ensured by annual audits.

- Dimension and Shape Tolerances -Yield Strength -Tensile Strength -Elongation	Product	General Conditions	Specific Conditions		Dimensions	Alloy
			Mechanical Specifications	Tolerance		
	Extrude Profile	EN 755-1	EN 755-2	EN 755-9	Thickness min 0.9 mm. Thickness max. 20.0 mm.	EN AW 6060 EN AW 6063 EN AW 6463



# Technisches Datenblatt

## 231454P Endklemme Blank mit Erdungspin 30 mm

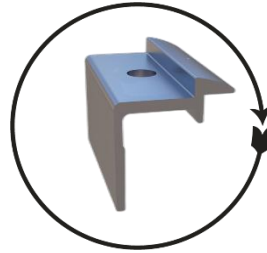

Endklemme Rahmenhöhe 30 mm  
6063 T66

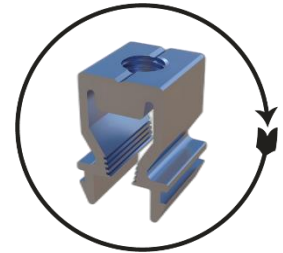

Spreizklemme  
6063 T66



Imbusschraube DIN 7380 M8X40  
A2 Edelstahl

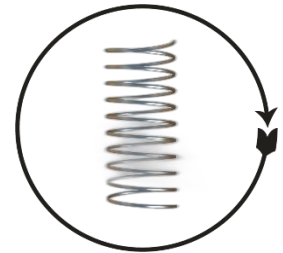

Feder A2 M8 20mm  
A2 Edelstahl

Art.Nr.	Bezeichnung	Material	Oberfläche	Stück/ Karton	Verpackung LXBXH	kg/ Stück
8253-P	Endklemme Rahmenhöhe 30 mm	EN AW 6063 T66	Blank	100	40 X 30 X 10	22,18
9513	Spreizklemme	EN AW 6063 T66	Blank	100		11,07
10190	Feder A2 M8 20mm	A2	Edelstahl	100		0,39
10105	Imbusschraube DIN 7380 M8X40	A2	Edelstahl	100		17,15

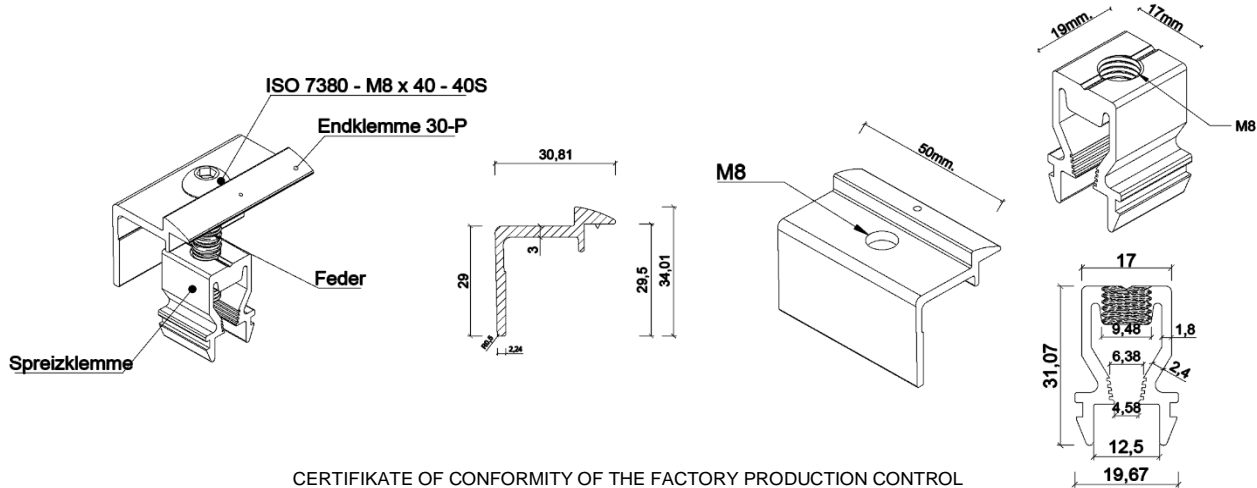

CERTIFICATE OF CONFORMITY OF THE FACTORY PRODUCTION CONTROL  
2674-CPR-233541

In compliance with Regulation (EU) No 305/2011 of the European Parliament and of the Council of 9 March 2011 (the Construction products Regulation od CPR), this certificate applies to the construction products.

CONSTRUCTION PRODUCT(S)

Scope of certificate : Aluminium and aluminium alloys-Structural products for construction Works

EN 150088:2005

under system 2+ are applied that

the factory production control is assessed to be conformity with the applicable requirements.

This certificate was first issued on <20.12.2023> and will remain valid as long as neither the harmonised standard, the construction product, the AVCP methods nor the manufacturing conditions in the plant are modified significantly, unless suspended or withdrawn by FQC Standard Uygunluk Degerlendirme A. Ş. The validity of the document is ensured by annual audits.

- Dimension and Shape Tolerances -Yield Strength -Tensile Strength -Elongation	Product	General Conditions	Specific Conditions		Dimensions	Alloy
			Mechanical Specifications	Tolerance		
	Extrude Profile	EN 755-1	EN 755-2	EN 755-9	Thickness min 0.9 mm. Thickness max. 20.0 mm.	EN AW 6060 EN AW 6063 EN AW 6463



# Technisches Datenblatt

## 231455 Endklemme Schwarz Eloxiert 30 mm Set



Endklemme Rahmenhöhe 30 mm  
6063 T66

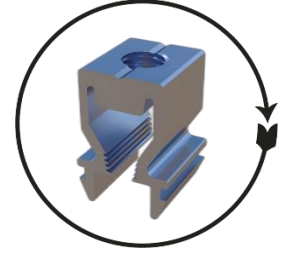

Spreizklemme  
6063 T66



Imbusschraube DIN 7380 M8X40  
A2 Edelstahl

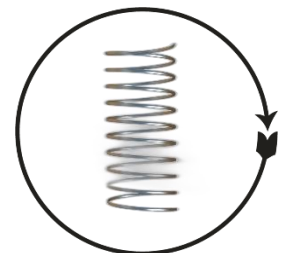

Feder A2 M8 20mm  
A2 Edelstahl

Art.Nr.	Bezeichnung	Material	Oberfläche	Stück/ Karton	Verpackung LXBXH	gr/ Stück
8254	Endklemme Rahmenhöhe 30 mm	EN AW 6063 T66	Schwarz Eloxiert	100	40 X 30 X 10	22,18
9513	Spreizklemme	EN AW 6063 T66	Blank	100		11,07
10190	Feder A2 M8 20mm	A2	Edelstahl	100		0,39
10105	Imbusschraube DIN 7380 M8X40	A2	Edelstahl	100		17,15

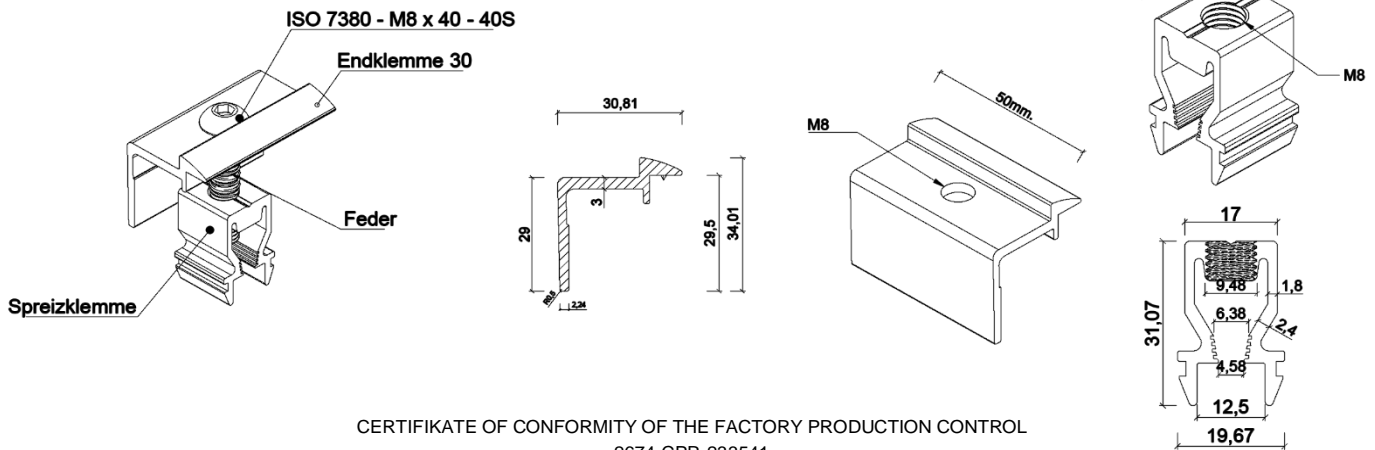

CERTIFIKATE OF CONFORMITY OF THE FACTORY PRODUCTION CONTROL  
2674-CPR-233541

In compliance with Regulation (EU) No 305/2011 of the European Parliament and of the Council of 9 March 2011 (the Construction products Regulation od CPR), this certificate applies to the construction products.

CONSTRUCTION PRODUCT(S)

Scope of certificate : Aluminium and aluminium alloys-Structural products for construction Works

EN 150088:2005

under system 2+ are applied that

the factory production control is assessed to be conformity with the applicable requirements.

This certificate was first issued on <20.12.2023> and will remain valid as long as neither the harmonised standard, the construction product, the AVCP methods nor the manufacturing conditions in the plant are modified significantly, unless suspended or withdrawn by FQC Standard Uygunluk Degerlendirme A. Ş. The validity of the document is ensured by annual audits.

- Dimension and Shape Tolerances -Yield Strength -Tensile Strength -Elongation	Product	General Conditions	Specific Conditions		Dimensions	Alloy
			Mechanical Specifications	Tolerance		
	Extrude Profile	EN 755-1	EN 755-2	EN 755-9	Thickness min 0.9 mm. Thickness max. 20.0 mm.	EN AW 6060 EN AW 6063 EN AW 6463





# Technisches Datenblatt

## 231455P Endklemme Schwarz Eloxiert mit Erdungspin 30mm Set



Endklemme Rahmenhöhe 30 mm  
6063 T66

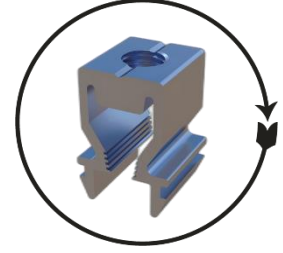

Spreizklemme  
6063 T66



Imbusschraube DIN 7380 M8X40  
A2 Edelstahl

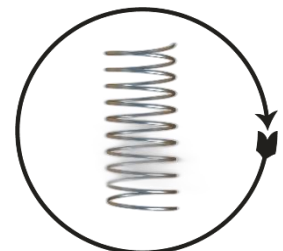

Feder A2 M8 20mm  
A2 Edelstahl

Art.Nr.	Bezeichnung	Material	Oberfläche	Stück/ Karton	Verpackung LXBXH	gr/ Stück
8254-P	Endklemme Rahmenhöhe 30 mm	EN AW 6063 T66	Schwarz Eloxiert	100	40 X 30 X 10	22,18
9513	Spreizklemme	EN AW 6063 T66	Blank	100		11,07
10190	Feder A2 M8 20mm	A2	Edelstahl	100		0,39
10105	Imbusschraube DIN 7380 M8X40	A2	Edelstahl	100		17,15

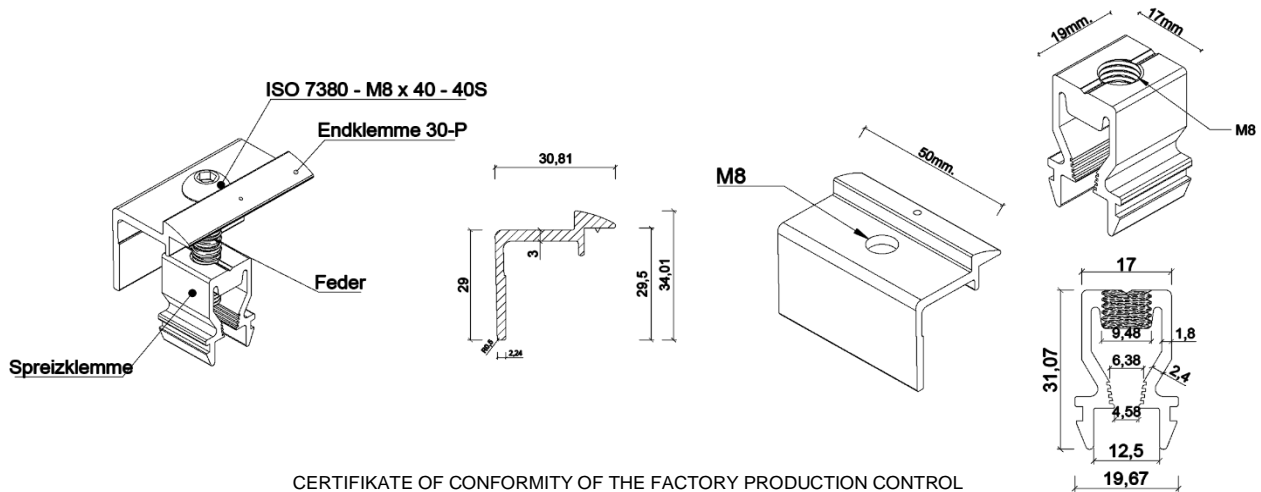

CERTIFICATE OF CONFORMITY OF THE FACTORY PRODUCTION CONTROL  
2674-CPR-233541

In compliance with Regulation (EU) No 305/2011 of the European Parliament and of the Council of 9 March 2011 (the Construction products Regulation od CPR), this certificate applies to the construction products.

CONSTRUCTION PRODUCT(S)

Scope of certificate : Aluminium and aluminium alloys-Structural products for construction Works

EN 150088:2005

under system 2+ are applied that

the factory production control is assessed to be conformity with the applicable requirements.

This certificate was first issued on <20.12.2023> and will remain valid as long as neither the harmonised standard, the construction product, the AVCP methods nor the manufacturing conditions in the plant are modified significantly, unless suspended or withdrawn by FQC Standard Uygunluk Degerlendirme A. Ş. The validity of the document is ensured by annual audits.

- Dimension and Shape Tolerances -Yield Strength -Tensile Strength -Elongation	Product	General Conditions	Specific Conditions		Dimensions	Alloy
			Mechanical Specifications	Tolerance		
	Extrude Profile	EN 755-1	EN 755-2	EN 755-9	Thickness min 0.9 mm. Thickness max. 20.0 mm.	EN AW 6060 EN AW 6063 EN AW 6463



## 231923 Mittelklemme Blank Set

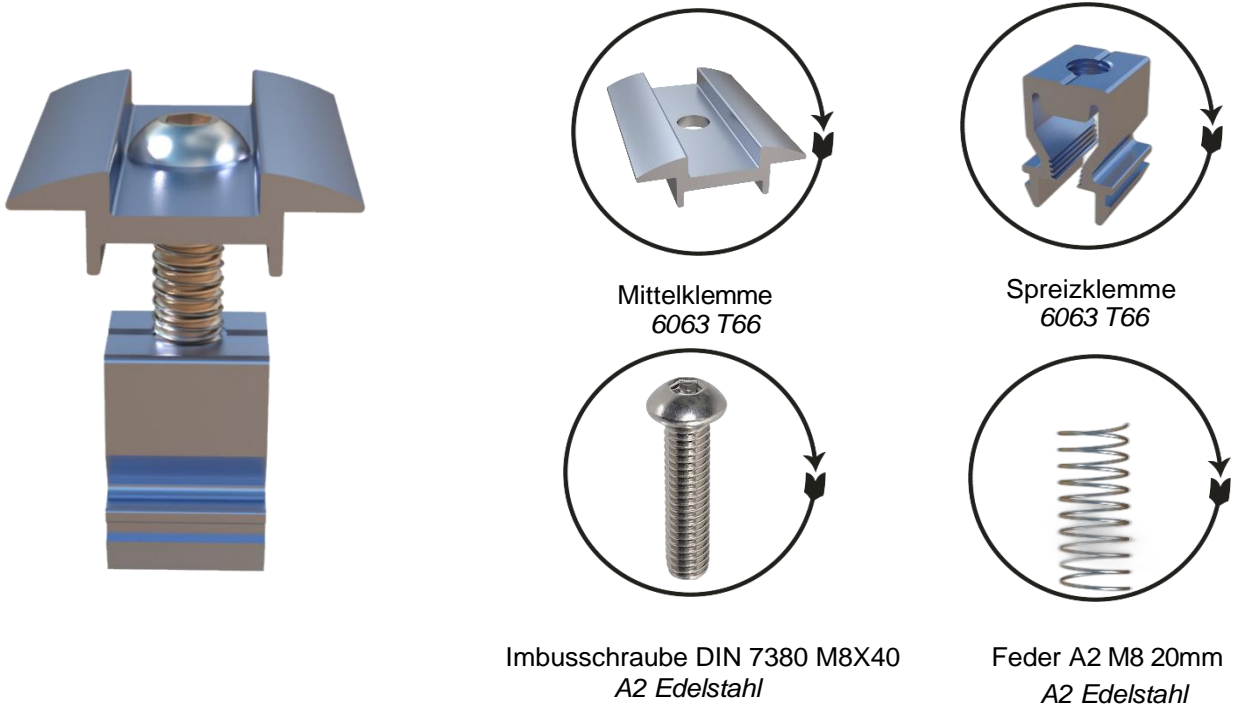

Art.Nr.	Bezeichnung	Material	Oberfläche	Stück/ Karton	Verpackung LXBXH	g/ Stück
8402	Mittelklemme Blank	EN AW 6063 T66	Blank	100	40 X 30 X 10	19,22
9513	Spreizklemme	EN AW 6063 T66	Blank	100		11,07
10190	Feder A2 M8 20mm	A2	Edelstahl	100		0,39
10105	Imbusschraube DIN 7380 M8X40	A2	Edelstahl	100		17,15

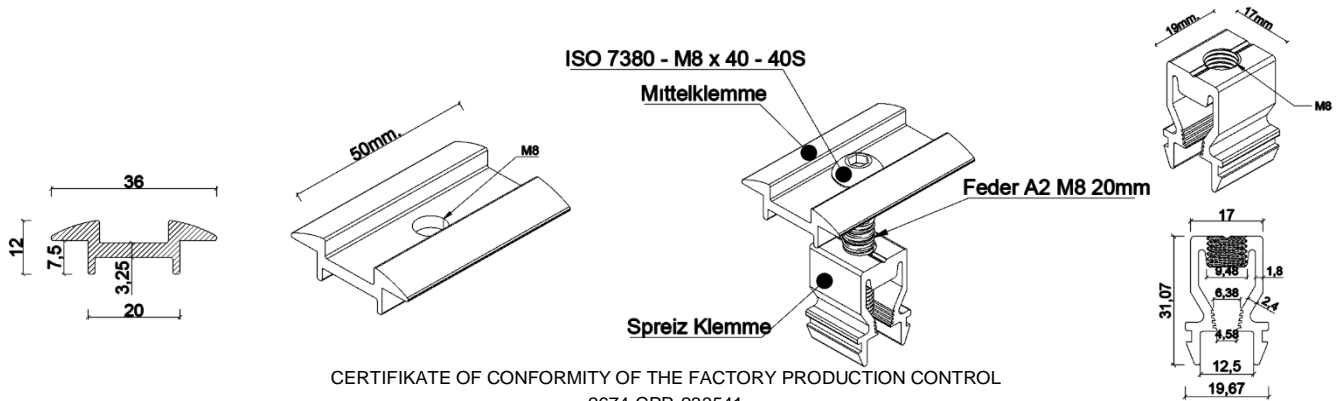

CERTIFICATE OF CONFORMITY OF THE FACTORY PRODUCTION CONTROL  
2674-CPR-233541

In compliance with Regulation (EU) No 305/2011 of the European Parliament and of the Council of 9 March 2011 (the Construction products Regulation od CPR), this certificate applies to the construction products.

CONSTRUCTION PRODUCT(S)

Scope of certificate : Aluminium and aluminium alloys-Structural products for construction Works

EN 150088:2005

under system 2+ are applied that

the factory production control is assessed to be conformity with the applicable requirements.

This certificate was first issued on <20.12.2023> and will remain valid as long as neither the harmonised standard, the construction product, the AVCP methods nor the manufacturing conditions in the plant are modified significantly, unless suspended or withdrawn by FQC Standard Uygunluk Degerlendirme A. Ş. The validity of the document is ensured by annual audits.

- Dimension and Shape Tolerances -Yield Strength -Tensile Strength -Elongation	Product	General Conditions	Specific Conditions		Dimensions	Alloy
			Mechanical Specifications	Tolerance		
	Extrude Profile	EN 755-1	EN 755-2	EN 755-9	Thickness min 0.9 mm. Thickness max. 20.0 mm.	EN AW 6060 EN AW 6063 EN AW 6463



# Technisches Datenblatt

## 231923P Mittelklemme Blank mit Erdungspin Set

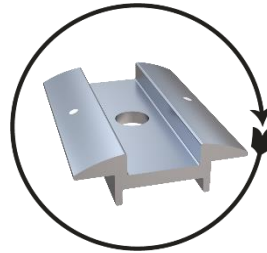
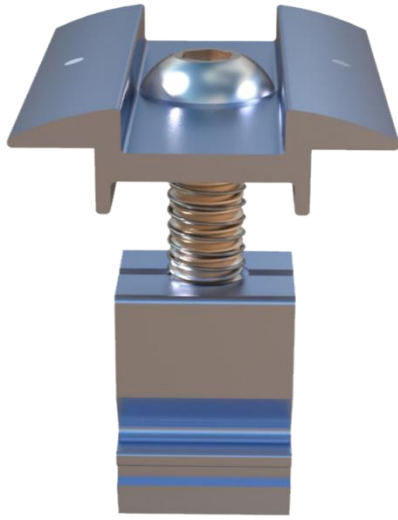

Mittelklemme-P  
6063 T66

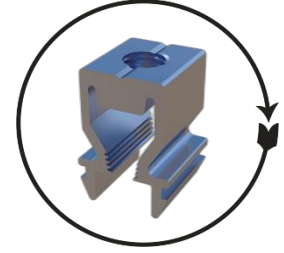

Spreizklemme  
6063 T66



Inbusschraube DIN 7380 M8X40  
A2 Edelstahl

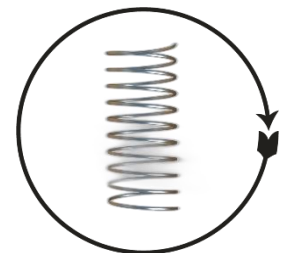

Feder A2 M8 20mm  
A2 Edelstahl

Art.Nr.	Bezeichnung	Material	Oberfläche	Stück/ Karton	Verpackung LXBXH	gr/ Stück
8402-P	Mittelklemme	EN AW 6063 T66	Blank	100	40 X 30 X 10	19,22
9513	Spreizklemme	EN AW 6063 T66	Blank	100		11,07
10190	Feder A2 M8 20mm	A2	Edelstahl	100		0,39
10105	Inbusschraube DIN 7380 M8X40	A2	Edelstahl	100		17,15

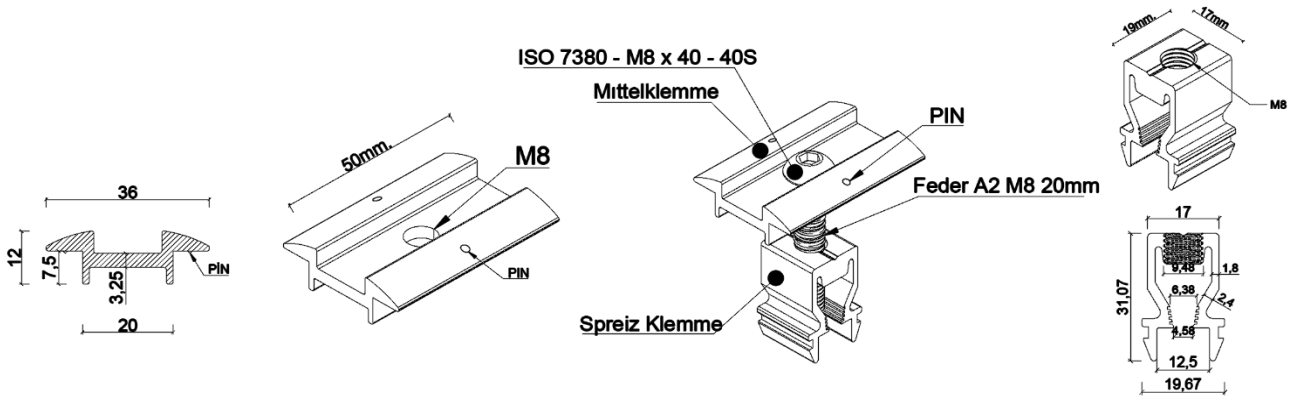

CERTIFIKATE OF CONFORMITY OF THE FACTORY PRODUCTION CONTROL  
2674-CPR-233541

In compliance with Regulation (EU) No 305/2011 of the European Parliament and of the Council of 9 March 2011 (the Construction products Regulation od CPR), this certificate applies to the construction products.

CONSTRUCTION PRODUCT(S)

Scope of certificate : Aluminium and aluminium alloys-Structural products for construction Works

EN 150088:2005

under system 2+ are applied that

the factory production control is assessed to be conformity with the applicable requirements.

This certificate was first issued on <20.12.2023> and will remain valid as long as neither the harmonised standard, the construction product, the AVCP methods nor the manufacturing conditions in the plant are modified significantly, unless suspended or withdrawn by FQC Standard Uygunluk Degerlendirme A. Ş. The validity of the document is ensured by annual audits.

- Dimension and Shape Tolerances -Yield Strength -Tensile Strength -Elongation	Product	General Conductions	Specific Conductions		Dimensions	Alloy
			Mechanical Specifications	Tolerance		
	Extrude Profile	EN 755-1	EN 755-2	EN 755-9	Thickness min 0.9 mm. Thickness max. 20.0 mm.	EN AW 6060 EN AW 6063 EN AW 6463



# Technisches Datenblatt

## 231924 Mittelklemme Schwarz Eloxiert Set



Mittelklemme  
6063 T66

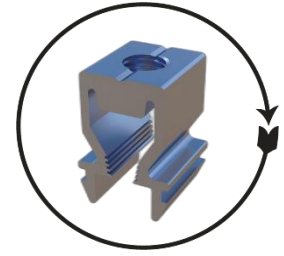

Spreizklemme  
6063 T66



Imbusschraube DIN 7380 M8X40  
A2 Edelstahl

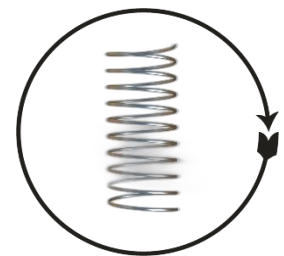

Feder A2 M8 20mm  
A2 Edelstahl

Art.Nr.	Bezeichnung	Material	Oberfläche	Stück/ Karton	Verpackung LXBXH	gr/ Stück
8403	Mittelklemme	EN AW 6063 T66	Schwarz Eloxiert	100	40 X 30 X 10	19,22
9513	Spreizklemme	EN AW 6063 T66	Blank	100		11,07
10190	Feder A2 M8 20mm	A2	Edelstahl	100		0,39
10105	Imbusschraube DIN 7380 M8X40	A2	Edelstahl	100		17,15

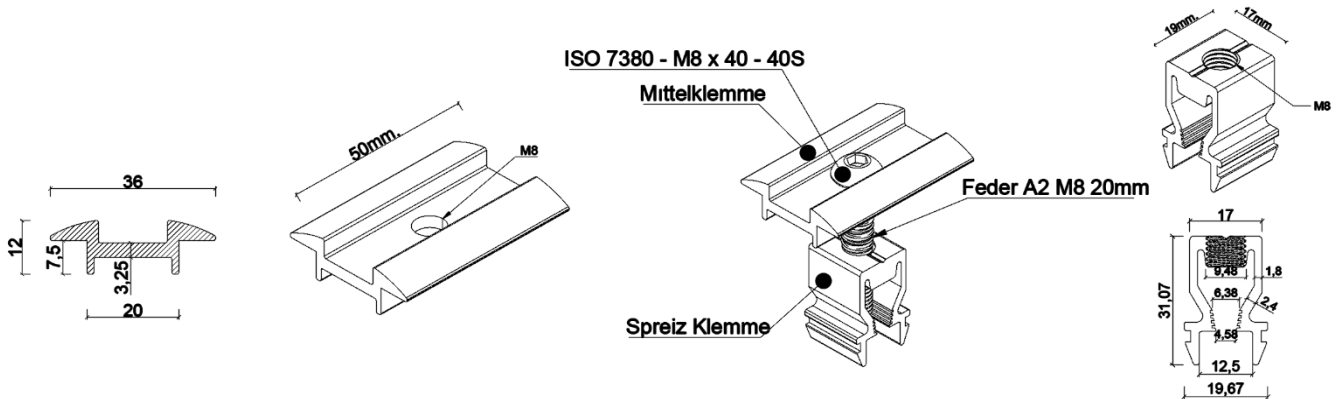

CERTIFIKATE OF CONFORMITY OF THE FACTORY PRODUCTION CONTROL  
2674-CPR-233541

In compliance with Regulation (EU) No 305/2011 of the European Parliament and of the Council of 9 March 2011 (the Construction products Regulation od CPR), this certificate applies to the construction products.

CONSTRUCTION PRODUCT(S)

Scope of certificate : Aluminium and aluminium alloys-Structural products for construction Works

EN 150088:2005

under system 2+ are applied that

the factory production control is assessed to be conformity with the applicable requirements.

This certificate was first issued on <20.12.2023> and will remain valid as long as neither the harmonised standard, the construction product, the AVCP methods nor the manufacturing conditions in the plant are modified significantly, unless suspended or withdrawn by FQC Standard Uygunluk Degerlendirme A. Ş. The validity of the document is ensured by annual audits.

- Dimension and Shape Tolerances -Yield Strength -Tensile Strength -Elongation	Product  Extrude Profile	General Conductions  EN 755-1	Specific Conductions		Dimensions  Thickness min 0.9 mm. Thickness max. 20.0 mm.	Alloy  EN AW 6060 EN AW 6063 EN AW 6463
			Mechanical Specifinations	Tolarance		
			EN 755-2	EN 755-9		



# Technisches Datenblatt

## 231924P Mittelklemme Schwarz Eloxiert mit Erdungspin Set



Mittelklemme-P  
6063 T66

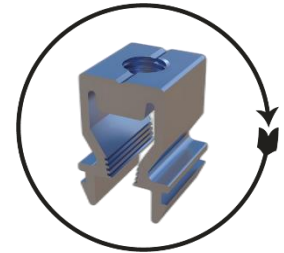

Spreizklemme  
6063 T66



Inbusschraube DIN 7380 M8X40  
A2 Edelstahl

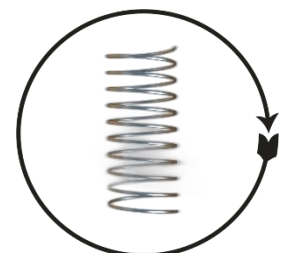

Feder A2 M8 20mm  
A2 Edelstahl

Art.Nr.	Bezeichnung	Material	Oberfläche	Stück/ Karton	Verpackung LXBXH	gr/ Stück
8403-P	Mittelklemme	EN AW 6063 T66	Schwarz Eloxiert	100	40 X 30 X 10	19,22
9513	Spreizklemme	EN AW 6063 T66	Blank	100		11,07
10190	Feder A2 M8 20mm	A2	Edelstahl	100		0,39
10105	Inbusschraube DIN 7380 M8X40	A2	Edelstahl	100		17,15

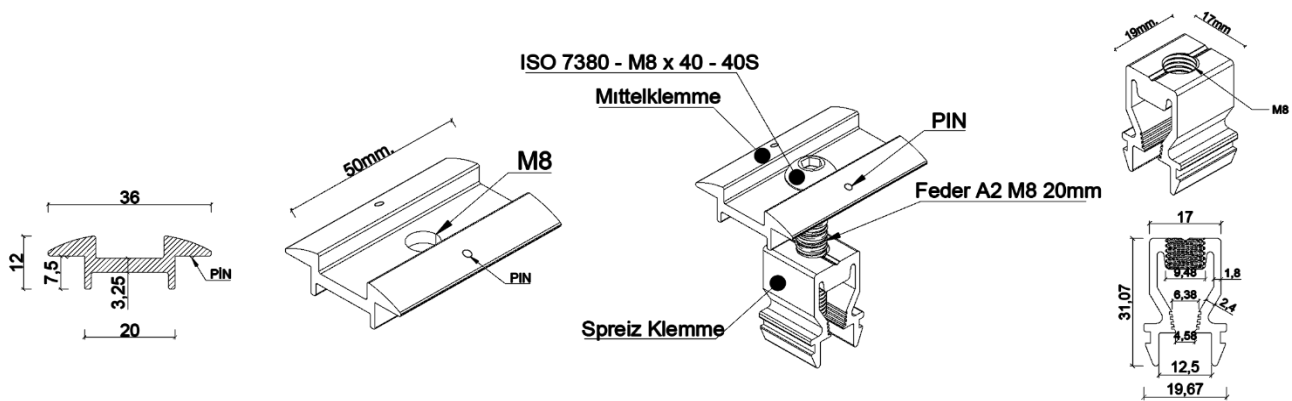

CERTIFIKATE OF CONFORMITY OF THE FACTORY PRODUCTION CONTROL  
2674-CPR-233541

In compliance with Regulation (EU) No 305/2011 of the European Parliament and of the Council of 9 March 2011 (the Construction products Regulation od CPR), this certificate applies to the construction products.

CONSTRUCTION PRODUCT(S)

Scope of certificate : Aluminium and aluminium alloys-Structural products for construction Works

EN 150088:2005

under system 2+ are applied that

the factory production control is assessed to be conformity with the applicable requirements.

This certificate was first issued on <20.12.2023> and will remain valid as long as neither the harmonised standard, the construction product, the AVCP methods nor the manufacturing conditions in the plant are modified significantly, unless suspended or withdrawn by FQC Standard Uygunluk Degerlendirme A. Ş. The validity of the document is ensured by annual audits.

- Dimension and Shape Tolerances -Yield Strength -Tensile Strength -Elongation	Product  Extrude Profile	General Conductions  EN 755-1	Specific Conductions		Dimensions  Thickness min 0.9 mm. Thickness max. 20.0 mm.	Alloy  EN AW 6060 EN AW 6063 EN AW 6463
			Mechanical Specifinations	Tolarance		
			EN 755-2	EN 755-9		



The background consists of large, abstract geometric shapes in orange and dark blue, creating a dynamic, angular pattern.

**Sandwich / Trapez  
und Stehfalzdächern**

# Technisches Datenblatt

## 8600 Kurzschiene mit EPDM 415 mm.

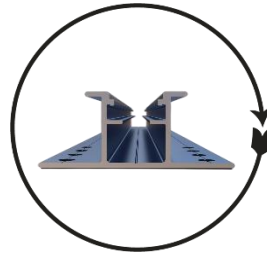

Kurzschiene EPDM 415mm.  
6063 T66

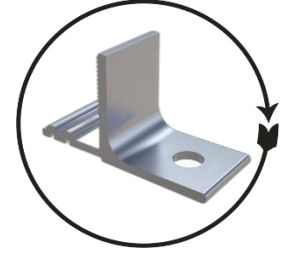

Kreuzverbinder M12  
6063 T66

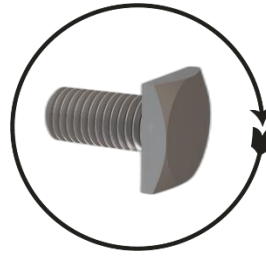

M12 Vierkantschraube  
A2 Edelstahl

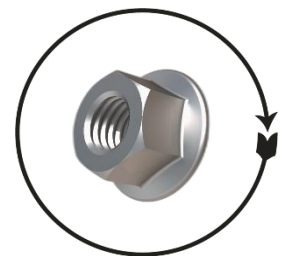

M12 Sechskantmutter mit Scheibe  
A2 Edelstahl

Art.Nr.	Bezeichnung	Material	Oberfläche	Stück/ Karton	Verpackung LXBXH	gr/ Stück
8600	Kurzschiene mit EPDM 415mm	EN AW 6063 T66	Blank	100	40 X 30 X 10	350
8255	Kreuzverbinder (M12)	EN AW 6063 T66	Blank	100		41,65
10200	M12 Vierkantschraube	A2	Edelstahl	100		41,98
10201	M12 Sechskantmutter mit Scheibe	A2	Edelstahl	100		12,69

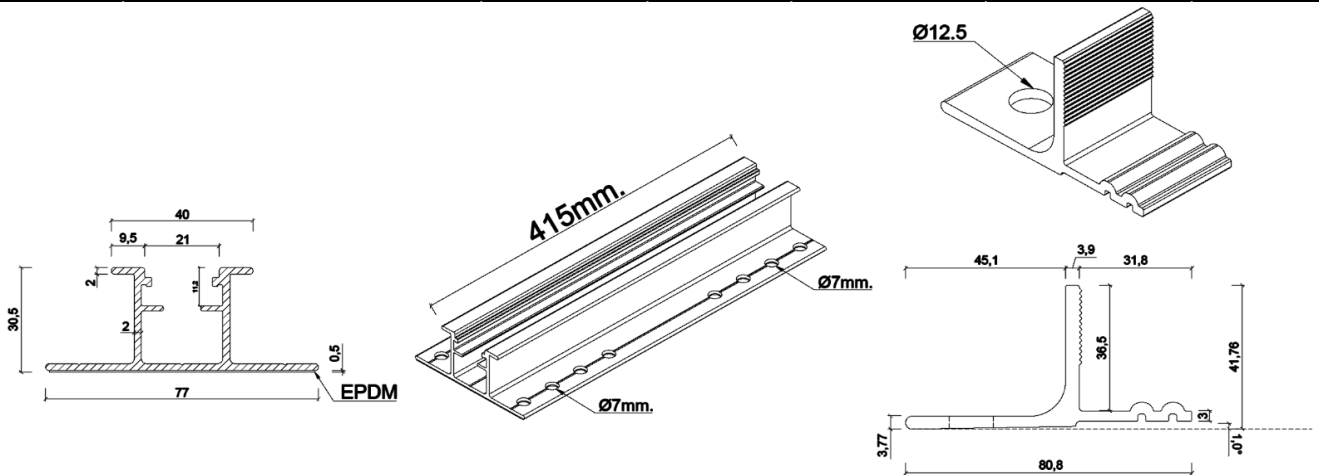

CERTIFIKATE OF CONFORMITY OF THE FACTORY PRODUCTION CONTROL  
2674-CPR-233541

In compliance with Regulation (EU) No 305/2011 of the European Parliament and of the Council of 9 March 2011 (the Construction products Regulation od CPR), this certificate applies to the construction products.

CONSTRUCTION PRODUCT(S)

Scope of certificate : Aluminium and aluminium alloys-Structural products for construction Works

EN 150088:2005

under system 2+ are applied that

the factory production control is assessed to be conformity with the applicable requirements.

This certificate was first issued on <20.12.2023> and will remain valid as long as neither the harmonised standard, the construction product, the AVCP methods nor the manufacturing conditions in the plant are modified significantly, unless suspended or withdrawn by FQC Standard Uygunluk Degerlendirme A. Ş. The validity of the document is ensured by annual audits.

- Dimension and Shape Tolerances -Yield Strength -Tensile Strength -Elongation	Product	General Conditions	Specific Conditions		Dimensions	Alloy
			Mechanical Specifications	Tolerance		
	Extrude Profile	EN 755-1	EN 755-2	EN 755-9	Thickness min 0.9 mm. Thickness max. 20.0 mm.	EN AW 6060 EN AW 6063 EN AW 6463







# Technisches Datenblatt

## 231928 Stehfalzklemme V1 Flach Set

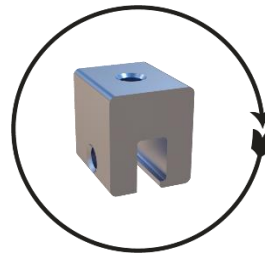
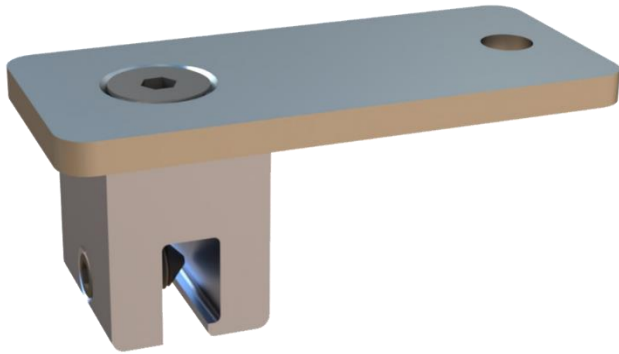

Stehfalzdachadapter  
6063 T66

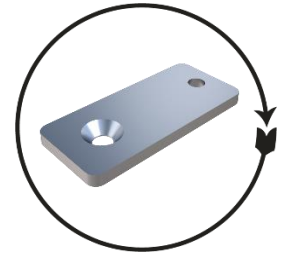

Aluminiumplatte  
6063 T66

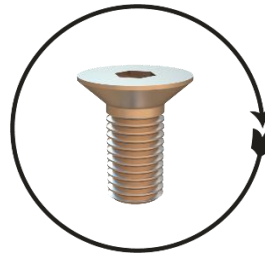

Gewindestift mit Innensechskant  
M8X16  
A2 Edelstahl

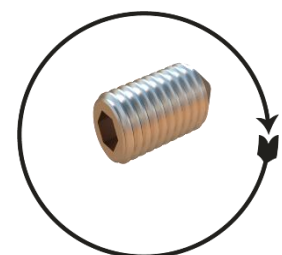

Sechskant-Senkkopfschraube mit  
Innensechskant M8X20  
A2 Edelstahl

Art.Nr.	Bezeichnung	Material	Oberfläche	Stück/ Karton	Verpackung LXBXH	gr/ Stück
8122	Stehfalzdachadapter	EN AW 6063 T66	Blank	50	60 X 40 X 10	46,63
8123	Aluminiumplatte	EN AW 6063 T66	Blank	50		45,68
8124	Gewindestift mit Innensechskant M8X16	A2	Edelstahl	50		4,31
8125	Sechskant-Senkkopfschraube mit Innensechskant M8X20	A2	Edelstahl	50		9,04

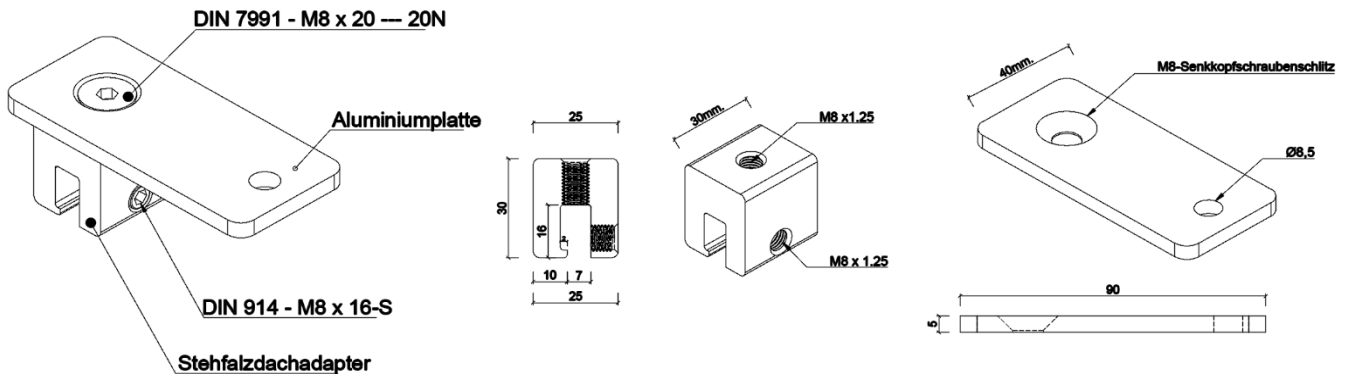

CERTIFIKATE OF CONFORMITY OF THE FACTORY PRODUCTION CONTROL  
2674-CPR-233541

In compliance with Regulation (EU) No 305/2011 of the European Parliament and of the Council of 9 March 2011 (the Construction products Regulation od CPR), this certificate applies to the construction products.

CONSTRUCTION PRODUCT(S)

Scope of certificate : Aluminium and aluminium alloys-Structural products for construction Works

EN 150088:2005

under system 2+ are applied that

the factory production control is assessed to be conformity with the applicable requirements.

This certificate was first issued on <20.12.2023> and will remain valid as long as neither the harmonised standard, the construction product, the AVCP methods nor the manufacturing conditions in the plant are modified significantly, unless suspended or withdrawn by FQC Standard Uygunluk Degerlendirme A. Ş. The validity of the document is ensured by annual audits.

- Dimension and Shape Tolerances -Yield Strength -Tensile Strength -Elongation	Product	General Conditions	Specific Conditions		Dimensions	Alloy
			Mechanical Specifications	Tolerance		
	Extrude Profile	EN 755-1	EN 755-2	EN 755-9	Thickness min 0.9 mm. Thickness max. 20.0 mm.	EN AW 6060 EN AW 6063 EN AW 6463



# Technisches Datenblatt

## 231929 Stehfalzklemme V2 L-Winkel

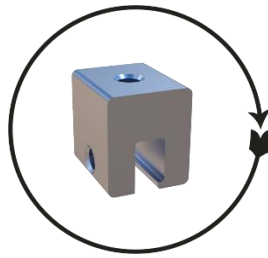
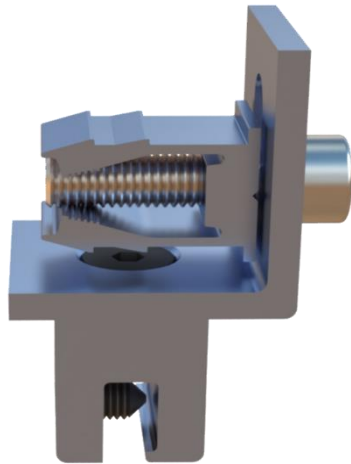

Stehfalzdachadapter  
6063 T66

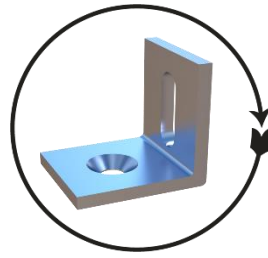

Aluminium L-Stück  
6063 T66

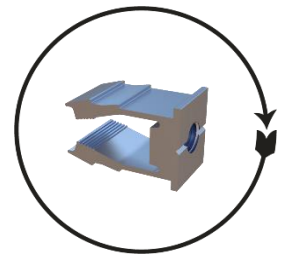

Spreizklemme M10  
6063 T66



Inbusschraube  
DIN 912 M10X40  
A2 Edelstahl

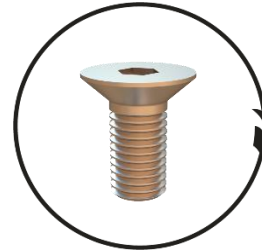

Gewindestift mit  
Innensechskant M8X16  
A2 Edelstahl

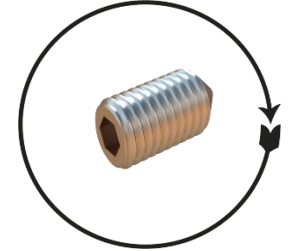

Sechskant-Senkkopfschraube mit  
Innensechskant M8X20  
A2 Edelstahl

Art.Nr.	Bezeichnung	Material	Oberfläche	Stück/ Karton	Verpackung LXBXH	gr/ Stück
8122	Stehfalzdachadapter	EN AW 6063 T66	Blank	50	60 X 40 X 10	46,63
8126	Aluminium L-Stück	EN AW 6063 T66	Blank	50		75,08
9514	Spreizklemme M10	EN AW 6063 T66	Blank	50		15,85
10103	Inbusschraube DIN 912 M10X40	A2	Edelstahl	50		35,16
8124	Gewindestift mit Innensechskant M8X16	A2	Edelstahl	50		4,31
8125	Sechskant-Senkkopfschraube mit Innensechskant M8X20	A2	Edelstahl	50		9,04

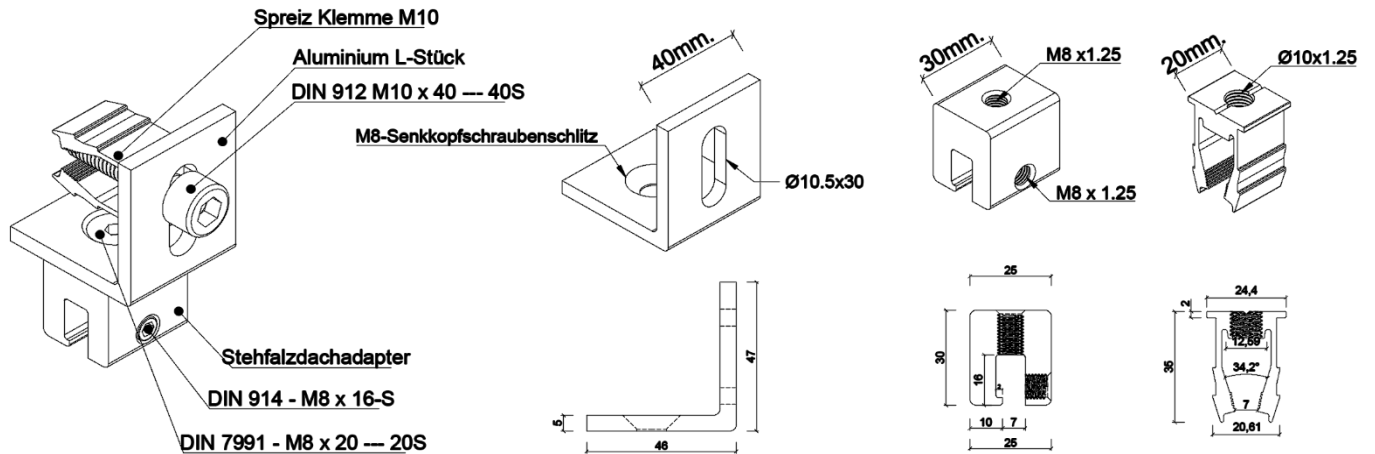

CERTIFICATE OF CONFORMITY OF THE FACTORY PRODUCTION CONTROL  
2674-CPR-233541

In compliance with Regulation (EU) No 305/2011 of the European Parliament and of the Council of 9 March 2011 (the Construction products Regulation od CPR), this certificate applies to the construction products.

CONSTRUCTION PRODUCT(S)

Scope of certificate : Aluminium and aluminium alloys-Structural products for construction Works

EN 150088:2005

under system 2+ are applied that

the factory production control is assessed to be conformity with the applicable requirements.

This certificate was first issued on <20.12.2023> and will remain valid as long as neither the harmonised standard, the construction product, the AVCP methods nor the manufacturing conditions in the plant are modified significantly, unless suspended or withdrawn by FQC Standard Uygunluk Degerlendirme A. Ş. The validity of the document is ensured by annual audits.

- Dimension and Shape Tolerances -Yield Strength -Tensile Strength -Elongation	Product	General Conductions	Specific Conductions		Dimensions	Alloy
			Mechanical Specifinations	Tolarance		
	Extrude Profile	EN 755-1	EN 755-2	EN 755-9	Thickness min 0.9 mm. Thickness max. 20.0 mm.	EN AW 6060 EN AW 6063 EN AW 6463



# Technisches Datenblatt

## 231930 Stefalzklebme V3 Round

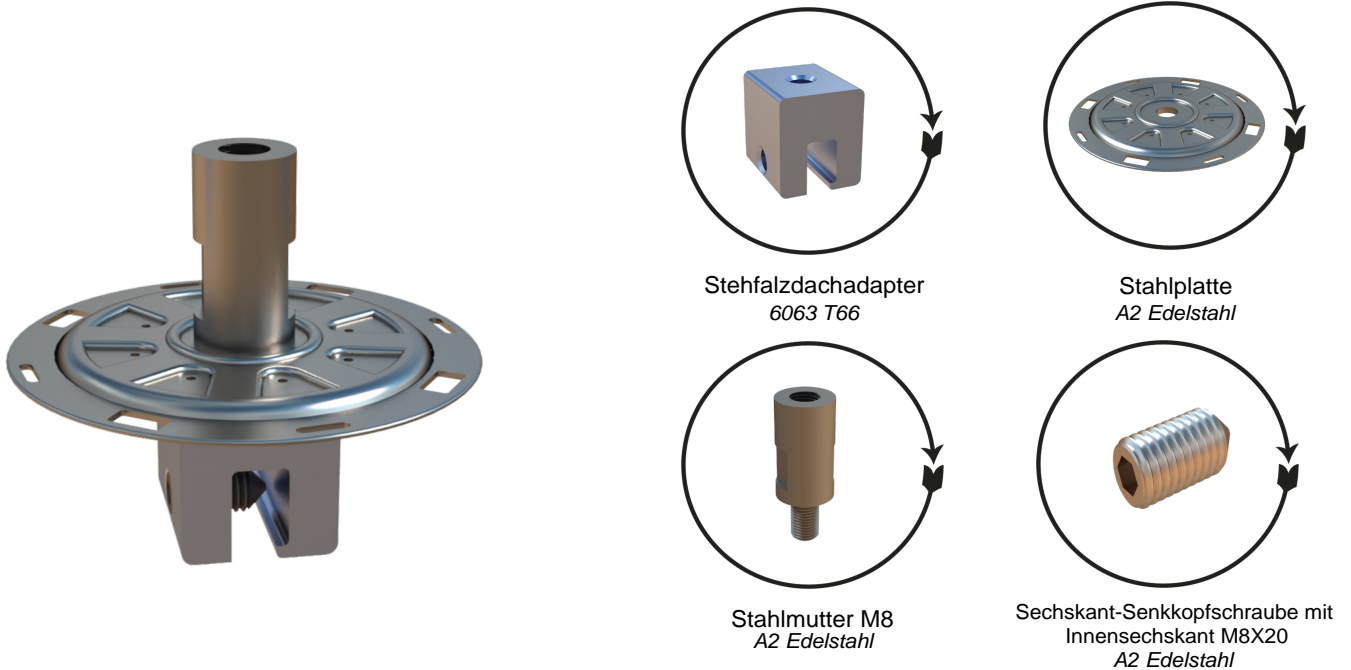

Art.Nr.	Bezeichnung	Material	Oberfläche	Stück/ Karton	Verpackung LXBXH	Gr/ Stück
8122	Stehfalzdachadapter	6063 T66	Pressblank	50	60x40x10	46,63
8127	Stahlplatte	Edelstahl	Edelstahl	50		33,99
8128	Stehlmutter M8	Edelstahl	Edelstahl	50		39,83
8124	Gewindestift mit Innensechskant M8X16	A2	Edelstahl	50		9,04

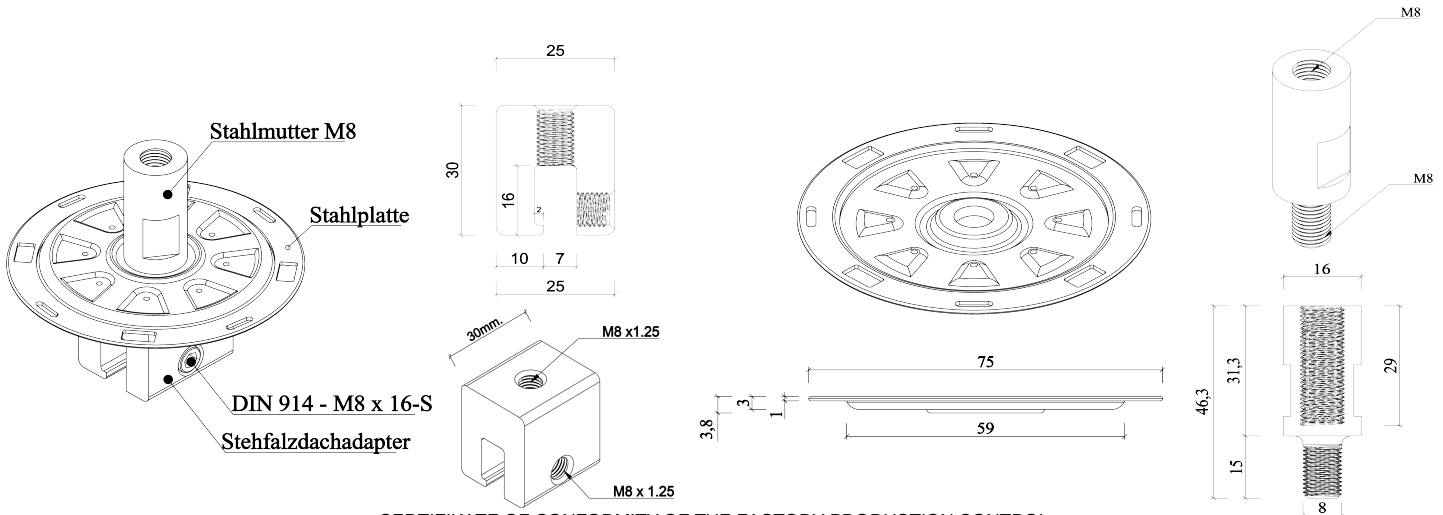

CERTIFICATE OF CONFORMITY OF THE FACTORY PRODUCTION CONTROL  
2674-CPR-233541

In compliance with Regulation (EU) No 305/2011 of the European Parliament and of the Council of 9 March 2011 (the Construction products Regulation od CPR), this certificate applies to the construction products.

CONSTRUCTION PRODUCT(S)

Scope of certificate : Aluminium and aluminium alloys-Structural products for construction Works

EN 150088:2005

under system 2+ are applied that

the factory production control is assessed to be conformity with the applicable requirements.

This certificate was first issued on <20.12.2023> and will remain valid as long as neither the harmonised standard, the construction product, the AVCP methods nor the manufacturing conditions in the plant are modified significantly, unless suspended or withdrawn by FQC Standard Uygunluk Degerlendirme A. Ş. The validity of the document is ensured by annual audits.

- Dimension and Shape Tolerances -Yield Strength -Tensile Strength -Elongation	Product	General Conductions	Specific Conductions		Dimensions	Alloy
			Mechanical Specifinations	Tolarance		
	Extrude Profile	EN 755-1	EN 755-2	EN 755-9	Thickness min 0.9 mm. Thickness max. 20.0 mm.	EN AW 6060 EN AW 6063 EN AW 6463



## 240225-Flachdach EWB NEO

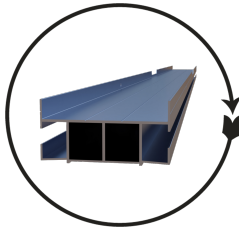
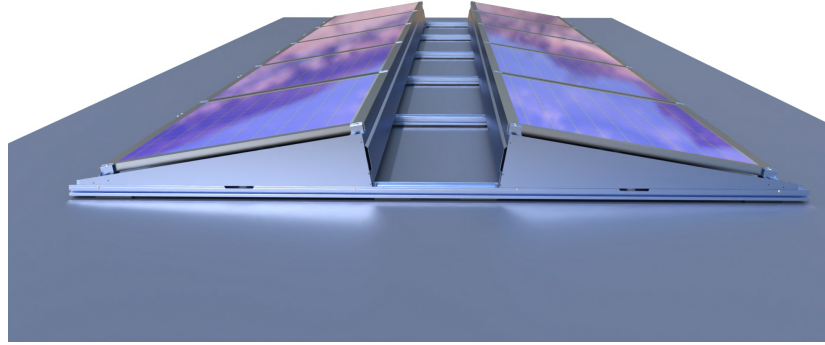

Montageschiene  
6063 T66

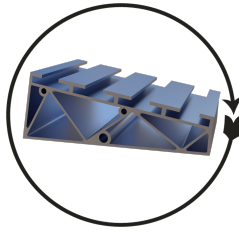

Front Stütze  
6063 T66

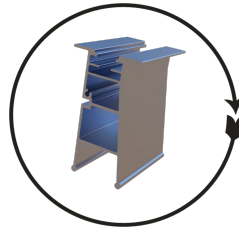

Stütze 2 Hinten  
6063 T66

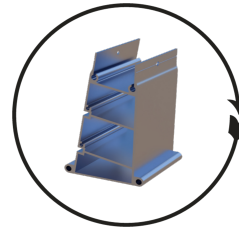

Stütze 1 Hinten  
6063 T66

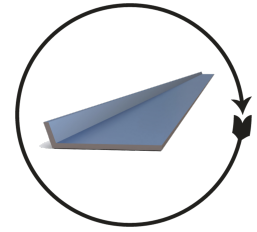

Ballaststein  
6063 T66

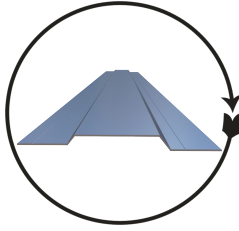

Windschutz Hinten  
6063 T66

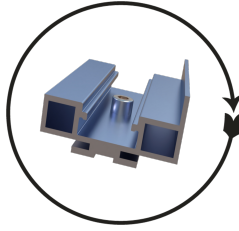

Front Stütze 1  
6063 T66

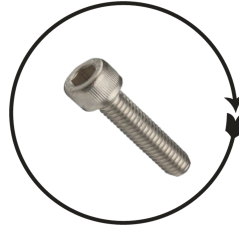

DIN 912 M6 x 10-10S  
A2 Edelstahl

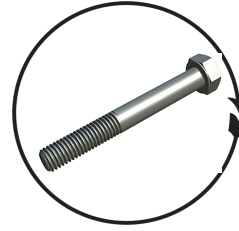

DIN EN 24016  
M6 x 60 x 18-WS

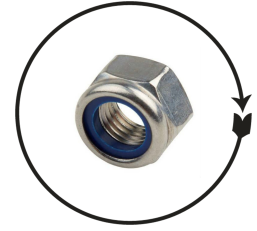

DIN EN ISO 7040 - M6 - C  
A2 Edelstahl

Bezeichnung	Material	Oberfläche	Stück/ Karton	Verpackung LXBXH	gr/ Stück
8130	Montageschiene 93.5 X 47,5 (1500mm.)	EN AW 6063 T66	Blank	1500 X 93,5 X 47,5	2.320
8131	Front Stütze	EN AW 6063 T66	Blank	136,5 X 90 X 48,8	300
8132	Stütze 1 Hinten	EN AW 6063 T66	Blank	91,5 X 90 X 125,5	340
8133	Stütze 2 Hinten	EN AW 6063 T66	Blank	61,5 X 90 X 146,8	250
8137	Front Stütze 1	EN AW 6063 T66	Blank	53,7 X 90 X 27,8	80
8134	Ballaststein	EN AW 6063 T66	Blank	1740 X 225 X 12,5	470
8135	Windschutz Hinten	EN AW 6063 T66	Blank	1740 X 45X 10	1.630
8136	Windschutz Seite	EN AW 6063 T66	Blank	1197 X 1,5 X 226,5	600
8138	Schienen Verbinder	EN AW 6063 T66	Blank	20 X 200 X 25	90
10110	DIN 912 M6 x 10 --- 10S	A2	Edelstahl		0
10108	DIN EN 24016 - M6 x 60 x 18-WS	A2	Edelstahl		0
10109	DIN EN ISO 7040 - M6 - C	A2	Edelstahl		0

CERTIFIKATE OF CONFORMITY OF THE FACTORY PRODUCTION CONTROL  
2674-CPR-233541

In compliance with Regulation (EU) No 305/2011 of the European Parliament and of the Council of 9 March 2011 (the Construction products Regulation od CPR), this certificate applies to the construction products.

CONSTRUCTION PRODUCT(S)

Scope of certificate : Aluminium and aluminium alloys-Structural products for construction Works

EN 15008:2005

under system 2+ are applied that

the factory production control is assessed to be conformity with the applicable requirements.

This certificate was first issued on <20.12.2023> and will remain valid as long as neither the harmonised standard, the construction product, the AVCP methods nor the manufacturing conditions in the plant are modified significantly, unless suspended or withdrawn by FQC Standard Uygunluk Degerlendirme A. Ş. The validity of the document is ensured by annual audits.

- Dimension and Shape Tolerances -Yield Strength -Tensile Strength -Elongation	Product	General Conditions	Specific Conditions		Dimensions	Alloy
			Mechanical Specifications	Tolerance		
	Extrude Profile	EN 755-1	EN 755-2	EN 755-9	Thickness min 0.9 mm. Thickness max. 20.0 mm.	EN AW 6060 EN AW 6063 EN AW 6463



## 240226-Flachdach SB NEO

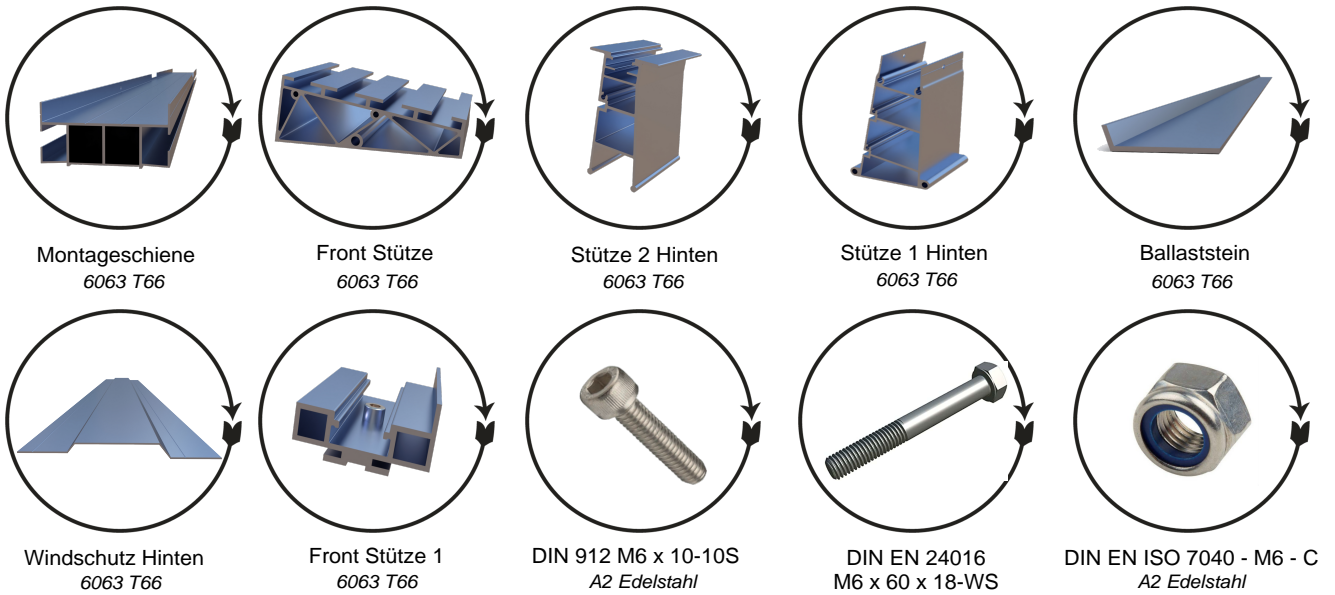
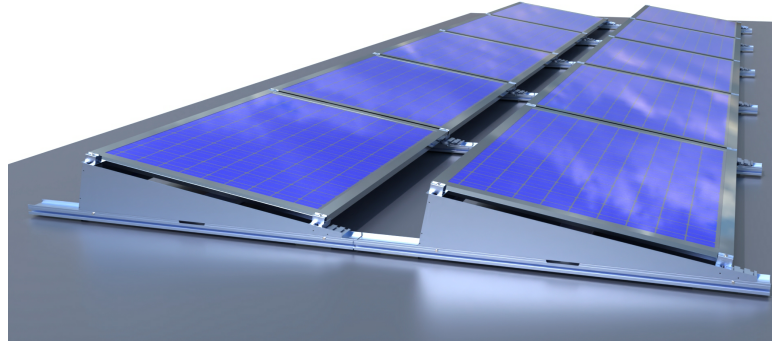

Bezeichnung	Material	Oberfläche	Stück/ Karton	Verpackung LXBXH	gr/ Stück
8130	Montageschiene 93.5 X 47,5 (1500mm.)	EN AW 6063 T66	Blank	1500 X 93,5 X 47,5	2.320
8131	Front Stütze	EN AW 6063 T66	Blank	136,5 X 90 X 48,8	300
8132	Stütze 1 Hinten	EN AW 6063 T66	Blank	91,5 X 90 X 125,5	340
8133	Stütze 2 Hinten	EN AW 6063 T66	Blank	61,5 X 90 X 146,8	250
8137	Front Stütze 1	EN AW 6063 T66	Blank	53,7 X 90 X 27,8	80
8134	Ballaststein	EN AW 6063 T66	Blank	1740 X 225 X 12,5	470
8135	Windschutz Hinten	EN AW 6063 T66	Blank	1740 X 45X 10	1.630
8136	Windschutz Seite	EN AW 6063 T66	Blank	1197 X 1,5 X 226,5	600
8138	Schienen Verbinder	EN AW 6063 T66	Blank	20 X 200 X 25	90
10110	DIN 912 M6 x 10 --- 10S	A2	Edelstahl		0
10108	DIN EN 24016 - M6 x 60 x 18-WS	A2	Edelstahl		0
10109	DIN EN ISO 7040 - M6 - C	A2	Edelstahl		0

CERTIFIKATE OF CONFORMITY OF THE FACTORY PRODUCTION CONTROL  
2674-CPR-233541

In compliance with Regulation (EU) No 305/2011 of the European Parliament and of the Council of 9 March 2011 (the Construction products Regulation od CPR), this certificate applies to the construction products.

CONSTRUCTION PRODUCT(S)

Scope of certificate : Aluminium and aluminium alloys-Structural products for construction Works

EN 150088:2005

under system 2+ are applied that

the factory production control is assessed to be conformity with the applicable requirements.

This certificate was first issued on <20.12.2023> and will remain valid as long as neither the harmonised standard, the construction product, the AVCP methods nor the manufacturing conditions in the plant are modified significantly, unless suspended or withdrawn by FQC Standard Uygunluk Degerlendirme A. Ş. The validity of the document is ensured by annual audits.

- Dimension and Shape Tolerances -Yield Strength -Tensile Strength -Elongation	Product	General Conditions	Specific Conditions		Dimensions	Alloy
			Mechanical Specifications	Tolerance		
	Extrude Profile	EN 755-1	EN 755-2	EN 755-9	Thickness min 0.9 mm. Thickness max. 20.0 mm.	EN AW 6060 EN AW 6063 EN AW 6463



## PV Zubehör

# Technisches Datenblatt

## 8103 Aluhalteplatte 850 mm mit Bohrung ( 1 x Links )

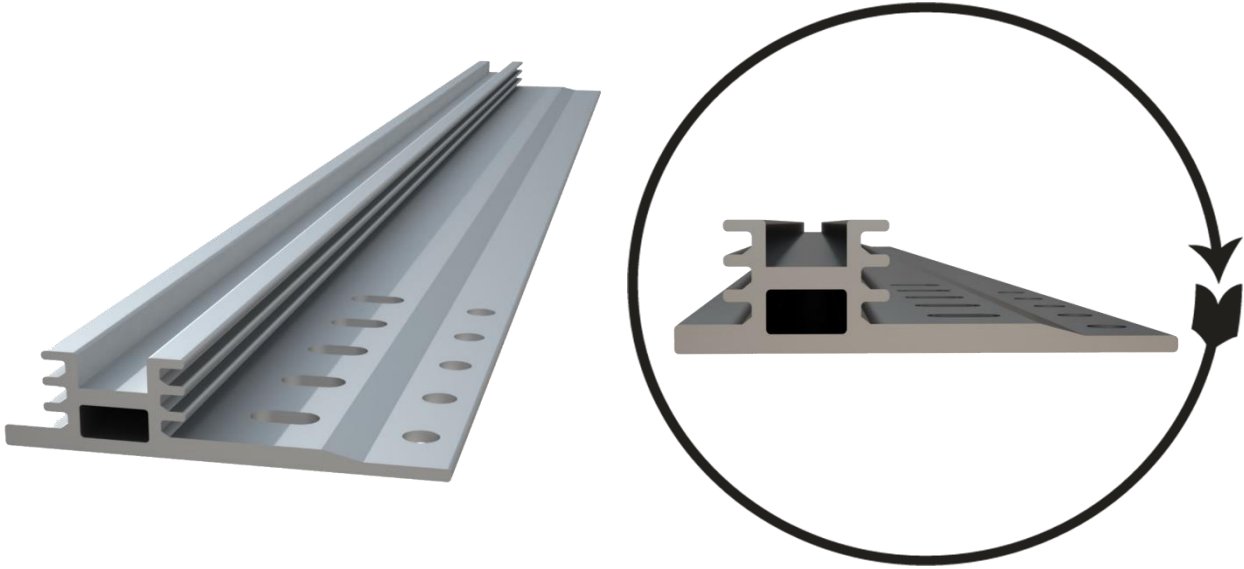

Aluhalteplatte 850mm. mit Bohrung ( 1 x links )  
6063 T66

Bezeichnung	Material	Oberfläche	Stück/ Karton	Verpackung LXBXH	kg/ Stück
Aluhalteplatte 850 mm mit Bohrung ( 1 x Links )	EN AW 6063 T66	Blank	140	120 X 80 X 350	1,911

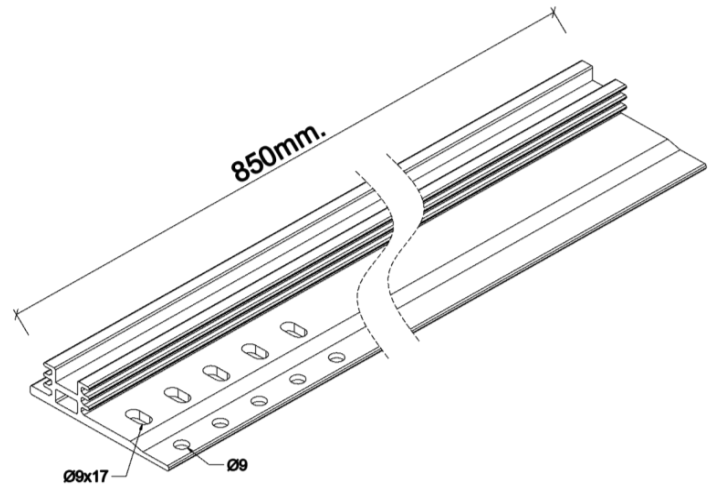
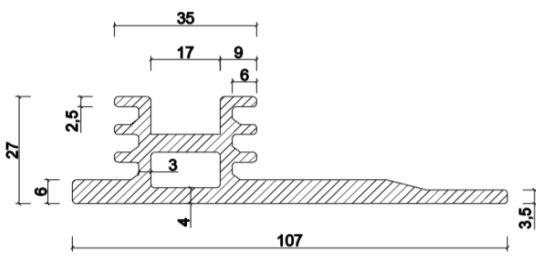

CERTIFIKATE OF CONFORMITY OF THE FACTORY PRODUCTION CONTROL  
2674-CPR-233541

In compliance with Regulation (EU) No 305/2011 of the European Parliament and of the Council of 9 March 2011 (the Construction products Regulation od CPR), this certificate applies to the construction products.

CONSTRUCTION PRODUCT(S)

Scope of certificate : Aluminium and aluminium alloys-Structural products for construction Works

EN 150088:2005

under system 2+ are applied that

the factory production control is assessed to be conformity with the applicable requirements.

This certificate was first issued on <20.12.2023> and will remain valid as long as neither the harmonised standard, the construction product, the AVCP methods nor the manufacturing conditions in the plant are modified significantly, unless suspended or withdrawn by FQC Standard Uygunluk Degerlendirme A. Ş. The validity of the document is ensured by annual audits.

- Dimension and Shape Tolerances -Yield Strength -Tensile Strength -Elongation	Product	General Conductions	Specific Conductions		Dimensions	Alloy
			Mechanical Specifinations	Tolarance		
	Extrude Profile	EN 755-1	EN 755-2	EN 755-9	Thickness min 0.9 mm. Thickness max. 20.0 mm.	EN AW 6060 EN AW 6063 EN AW 6463



# Technisches Datenblatt

## 8104 Alu Halteplatte 160mm

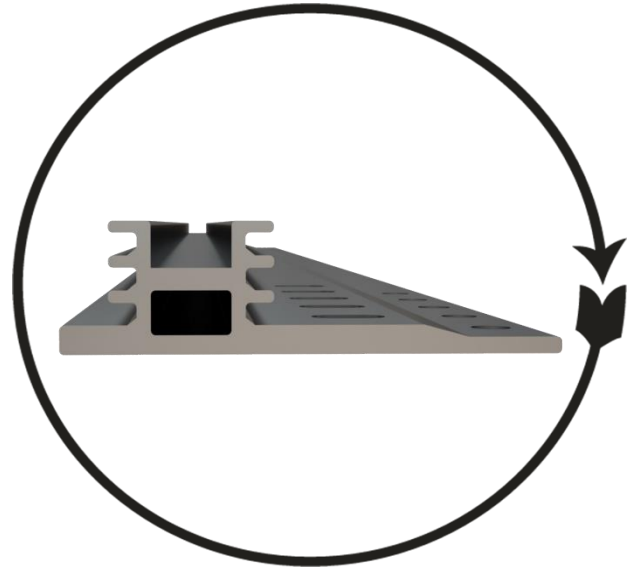
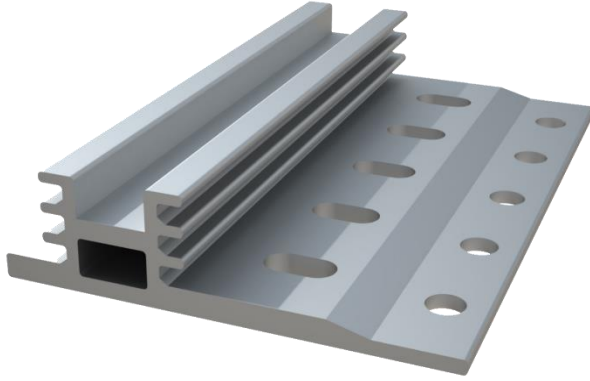

Alu Halteplatte 160mm  
6063 T66

Bezeichnung	Material	Oberfläche	Stück/ Karton	Verpackung LXBXH	gr/ Stück
Alu Halteplatte 160 mm	EN AW 6063 T66	Blank	24	40 X 30 X 10	351,34

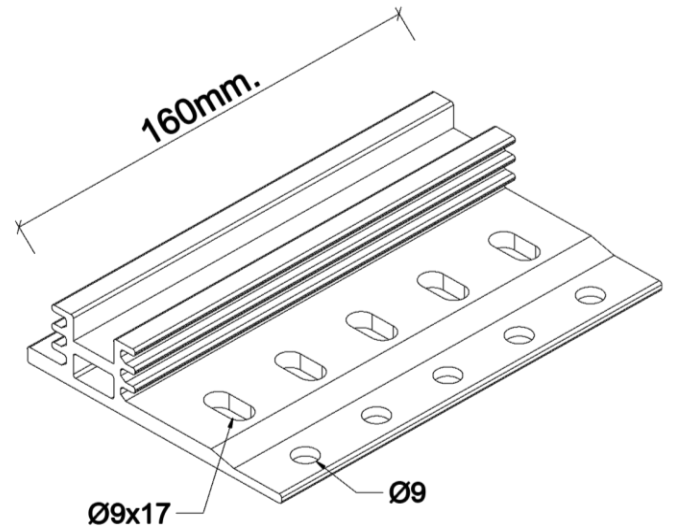
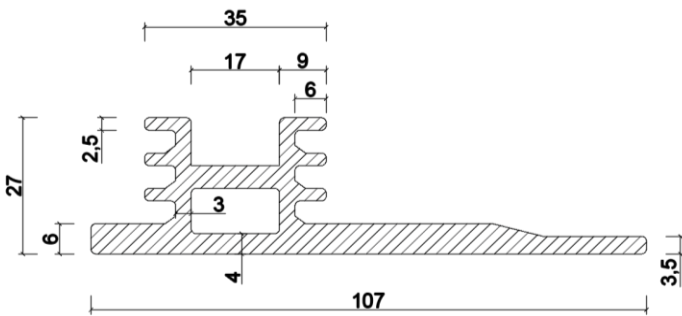

CERTIFIKATE OF CONFORMITY OF THE FACTORY PRODUCTION CONTROL  
2674-CPR-233541

In compliance with Regulation (EU) No 305/2011 of the European Parliament and of the Council of 9 March 2011 (the Construction products Regulation od CPR), this certificate applies to the construction products.

CONSTRUCTION PRODUCT(S)

Scope of certificate : Aluminium and aluminium alloys-Structural products for construction Works

EN 150088:2005

under system 2+ are applied that

the factory production control is assessed to be conformity with the applicable requirements.

This certificate was first issued on <20.12.2023> and will remain valid as long as neither the harmonised standard, the construction product, the AVCP methods nor the manufacturing conditions in the plant are modified significantly, unless suspended or withdrawn by FQC Standard Uygunluk Degerlendirme A. Ş. The validity of the document is ensured by annual audits.

- Dimension and Shape Tolerances -Yield Strength -Tensile Strength -Elongation	Product	General Conductions	Specific Conductions		Dimensions	Alloy
			Mechanical Specifications	Tolarance		
	Extrude Profile	EN 755-1	EN 755-2	EN 755-9	Thickness min 0.9 mm. Thickness max. 20.0 mm.	EN AW 6060 EN AW 6063 EN AW 6463





# Technisches Datenblatt

## 8109 Kreuzverbinder II

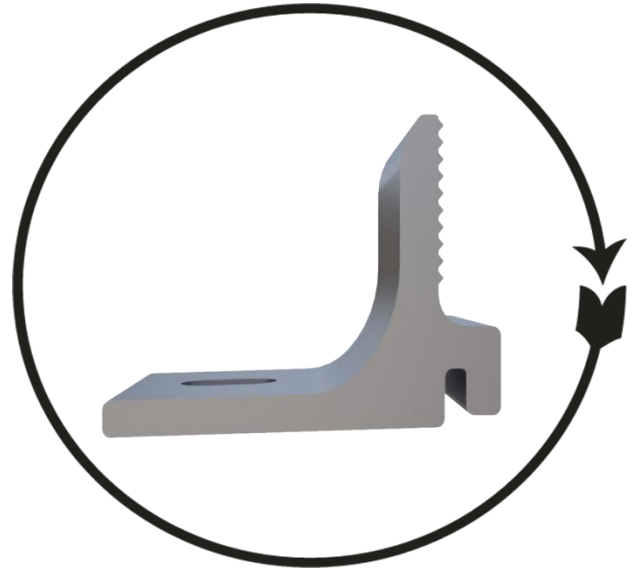
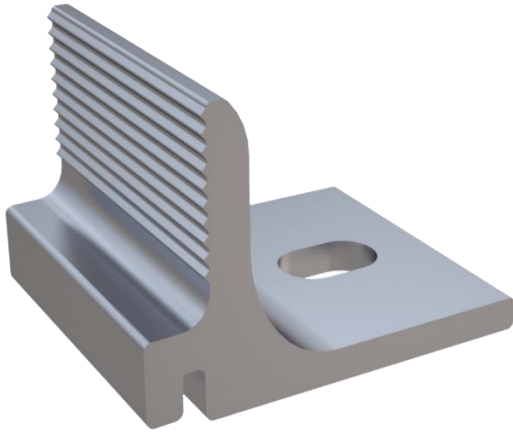

Kreuzverbinder II  
6063 T66

Bezeichnung	Material	Oberfläche	Stück/ Karton	Verpackung LXBXH	gr/ Stück
Kreuzverbinder II	EN AW 6063 T66	Blank	160	40 X 30 X 10	44,03

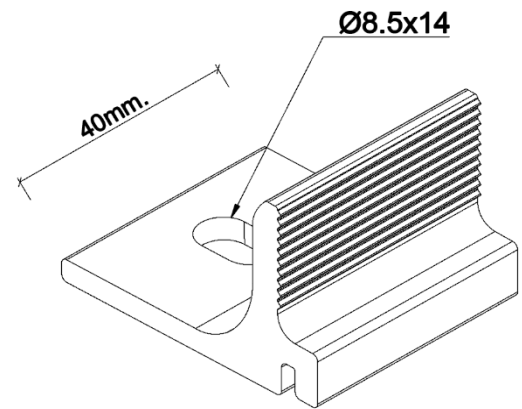
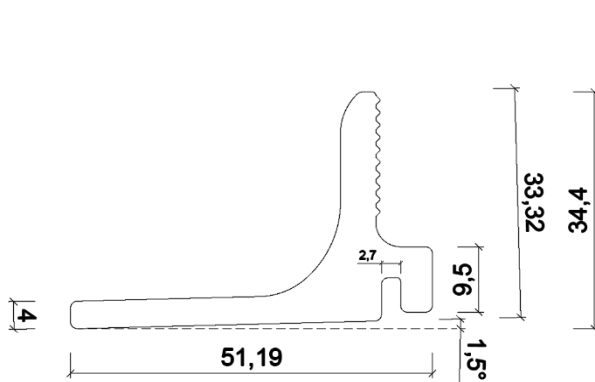

CERTIFIKATE OF CONFORMITY OF THE FACTORY PRODUCTION CONTROL  
2674-CPR-233541

In compliance with Regulation (EU) No 305/2011 of the European Parliament and of the Council of 9 March 2011 (the Construction products Regulation od CPR), this certificate applies to the construction products.

CONSTRUCTION PRODUCT(S)

Scope of certificate : Aluminium and aluminium alloys-Structural products for construction Works

EN 150088:2005

under system 2+ are applied that

the factory production control is assessed to be conformity with the applicable requirements.

This certificate was first issued on <20.12.2023> and will remain valid as long as neither the harmonised standard, the construction product, the AVCP methods nor the manufacturing conditions in the plant are modified significantly, unless suspended or withdrawn by FQC Standard Uygunluk Degerlendirme A. Ş. The validity of the document is ensured by annual audits.

- Dimension and Shape Tolerances -Yield Strength -Tensile Strength -Elongation	Product	General Conductions	Specific Conductions		Dimensions	Alloy
			Mechanical Specifinations	Tolarance		
	Extrude Profile	EN 755-1	EN 755-2	EN 755-9	Thickness min 0.9 mm. Thickness max. 20.0 mm.	EN AW 6060 EN AW 6063 EN AW 6463



# Technisches Datenblatt

## 8404 Mittelklemme Blank Universal

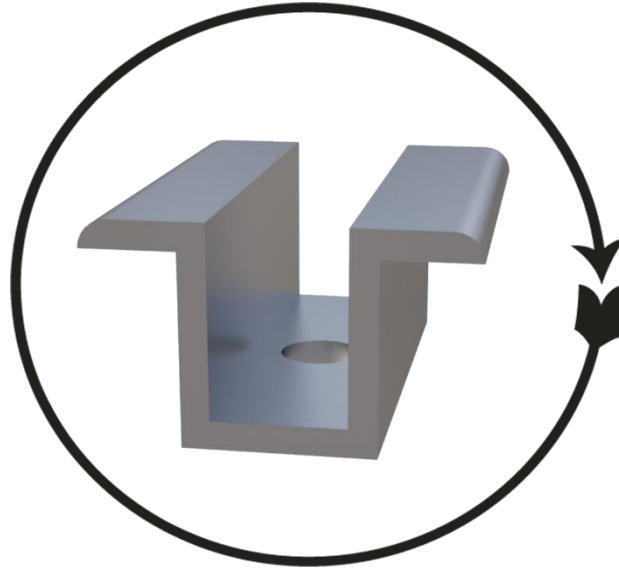

Mittelklemme Blank Universal  
6063 T66

Bezeichnung	Material	Oberfläche	Stück/ Karton	Verpackung LXBXH	gr/ Stück
Mittelklemme Blank Universal	EN AW 6063 T66	Blank	100	40 X 30 X 10	31,36

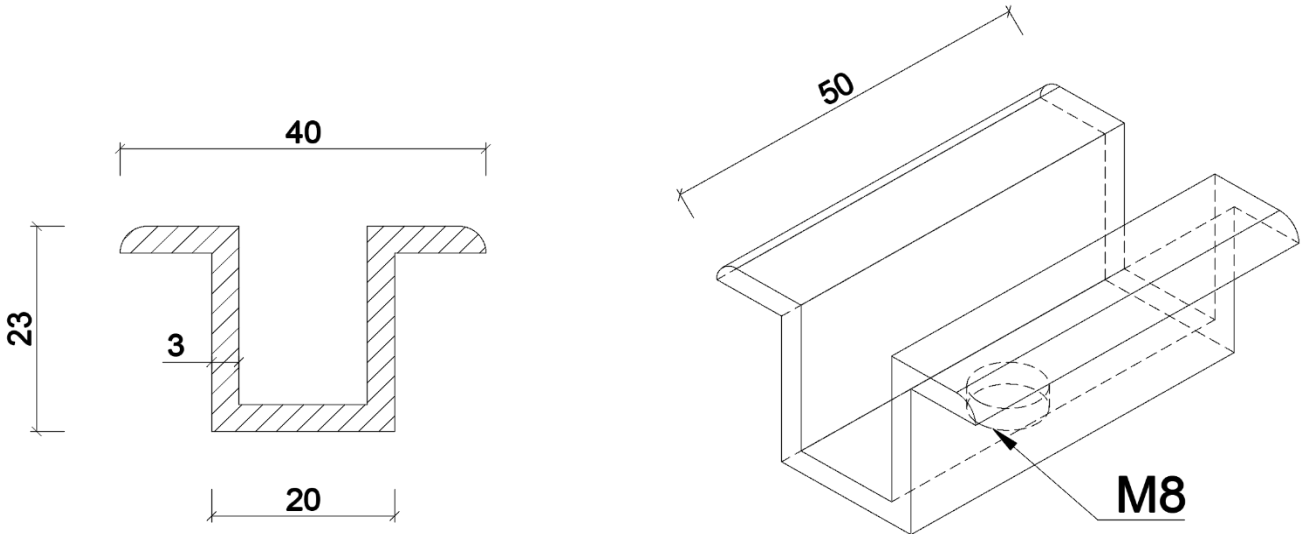

CERTIFIKATE OF CONFORMITY OF THE FACTORY PRODUCTION CONTROL  
2674-CPR-233541

In compliance with Regulation (EU) No 305/2011 of the European Parliament and of the Council of 9 March 2011 (the Construction products Regulation od CPR), this certificate applies to the construction products.

CONSTRUCTION PRODUCT(S)

Scope of certificate : Aluminium and aluminium alloys-Structural products for construction Works

EN 150088:2005

under system 2+ are applied that

the factory production control is assessed to be conformity with the applicable requirements.

This certificate was first issued on <20.12.2023> and will remain valid as long as neither the harmonised standard, the construction product, the AVCP methods nor the manufacturing conditions in the plant are modified significantly, unless suspended or withdrawn by FQC Standard Uygunluk Degerlendirme A. Ş. The validity of the document is ensured by annual audits.

- Dimension and Shape Tolerances -Yield Strength -Tensile Strength -Elongation	Product	General Conductions	Specific Conductions		Dimensions	Alloy
			Mechanical Specifications	Tolarance		
	Extrude Profile	EN 755-1	EN 755-2	EN 755-9	Thickness min 0.9 mm. Thickness max. 20.0 mm.	EN AW 6060 EN AW 6063 EN AW 6463



# Technisches Datenblatt

## 8405 Mittelklemme Universal Schwarz Eloxiert



### Mittelklemme Universal Schwarz Eloxiert 6063 T66

Bezeichnung	Material	Oberfläche	Stück/ Karton	Verpackung LXBXH	gr/ Stück
Mittelklemme Universal Schwarz Eloxiert	EN AW 6063 T66	Schwarz Eloxiert	100	40 X 30 X 10	31,36

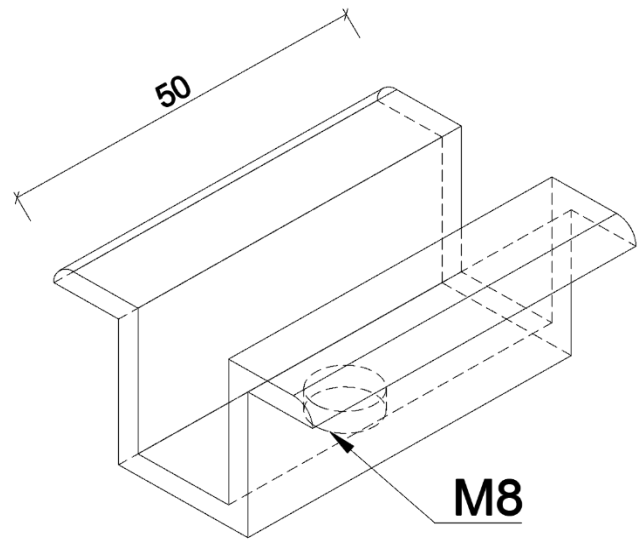
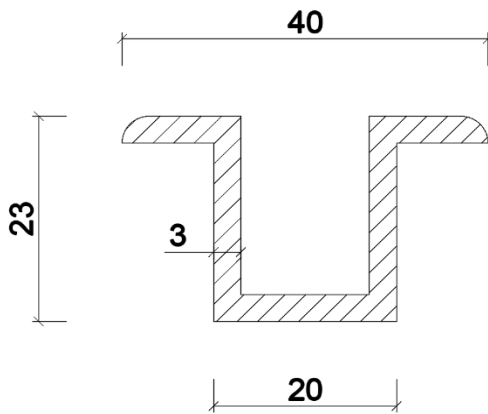

CERTIFIKATE OF CONFORMITY OF THE FACTORY PRODUCTION CONTROL  
2674-CPR-233541

In compliance with Regulation (EU) No 305/2011 of the European Parliament and of the Council of 9 March 2011 (the Construction products Regulation od CPR), this certificate applies to the construction products.

CONSTRUCTION PRODUCT(S)

Scope of certificate : Aluminium and aluminium alloys-Structural products for construction Works

EN 150088:2005

under system 2+ are applied that

the factory production control is assessed to be conformity with the applicable requirements.

This certificate was first issued on <20.12.2023> and will remain valid as long as neither the harmonised standard, the construction product, the AVCP methods nor the manufacturing conditions in the plant are modified significantly, unless suspended or withdrawn by FQC Standard Uygunluk Degerlendirme A. Ş. The validity of the document is ensured by annual audits.

- Dimension and Shape Tolerances -Yield Strength -Tensile Strength -Elongation	Product	General Conditions	Specific Conditions		Dimensions	Alloy
			Mechanical Specifications	Tolerance		
	Extrude Profile	EN 755-1	EN 755-2	EN 755-9	Thickness min 0.9 mm. Thickness max. 20.0 mm.	EN AW 6060 EN AW 6063 EN AW 6463



# Technisches Datenblatt

## 11000 Alu Rundleiter Ø8mm ( 155 M )



Bezeichnung	Material	Oberfläche	kg/ Stück
Alu Rundleiter Ø8mm ( 155 M )	AL_1xxx_Alloy_(H11)	Blank	36,26

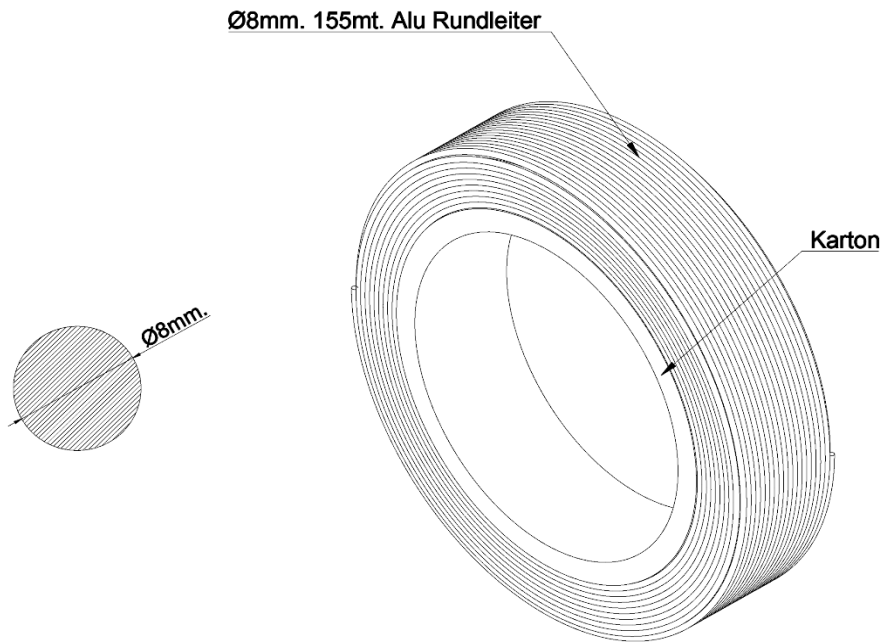

CERTIFIKATE OF CONFORMITY OF THE FACTORY PRODUCTION CONTROL  
2674-CPR-233541

In compliance with Regulation (EU) No 305/2011 of the European Parliament and of the Council of 9 March 2011 (the Construction products Regulation od CPR), this certificate applies to the construction products.

CONSTRUCTION PRODUCT(S)

Scope of certificate : Aluminium and aluminium alloys-Structural products for construction Works

EN 150088:2005

under system 2+ are applied that

the factory production control is assessed to be conformity with the applicable requirements.

This certificate was first issued on <20.12.2023> and will remain valid as long as neither the harmonised standard, the construction product, the AVCP methods nor the manufacturing conditions in the plant are modified significantly, unless suspended or withdrawn by FQC Standard Uygunluk Degerlendirme A. Ş. The validity of the document is ensured by annual audits.

- Dimension and Shape Tolerances -Yield Strength -Tensile Strength -Elongation	Product	General Condtions	Specific Condtions		Dimensions	Alloy
			Mechanical Specifications	Tolarance		
	Extrude Profile	EN 755-1	EN 755-2	EN 755-9	Thickness min 0.9 mm. Thickness max. 20.0 mm.	EN AW 6060 EN AW 6063 EN AW 6463



# Technisches Datenblatt

## 85030 Endklemme Blank Z Form 30 mm

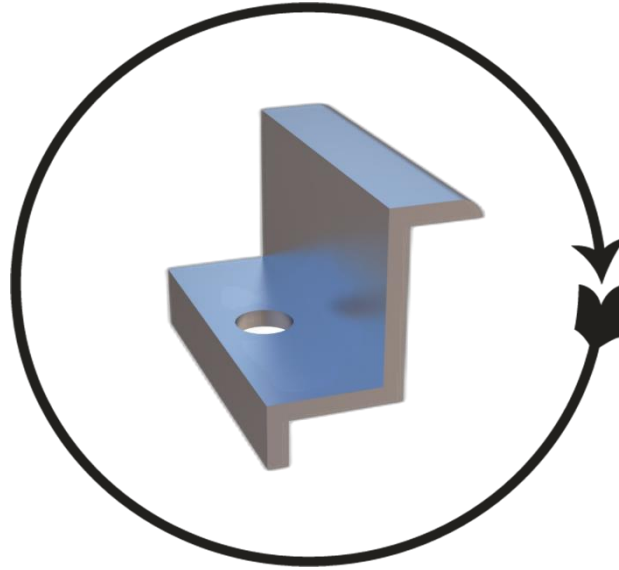

Endklemme Blank Z Form 30mm.  
6063 T66

Bezeichnung	Material	Oberfläche	Stück/ Karton	Verpackung LXBXH	gr/ Stück
Endklemme Z Form 30 mm	EN AW 6063 T66	Blank	100	40 X 30 X 10	27,15

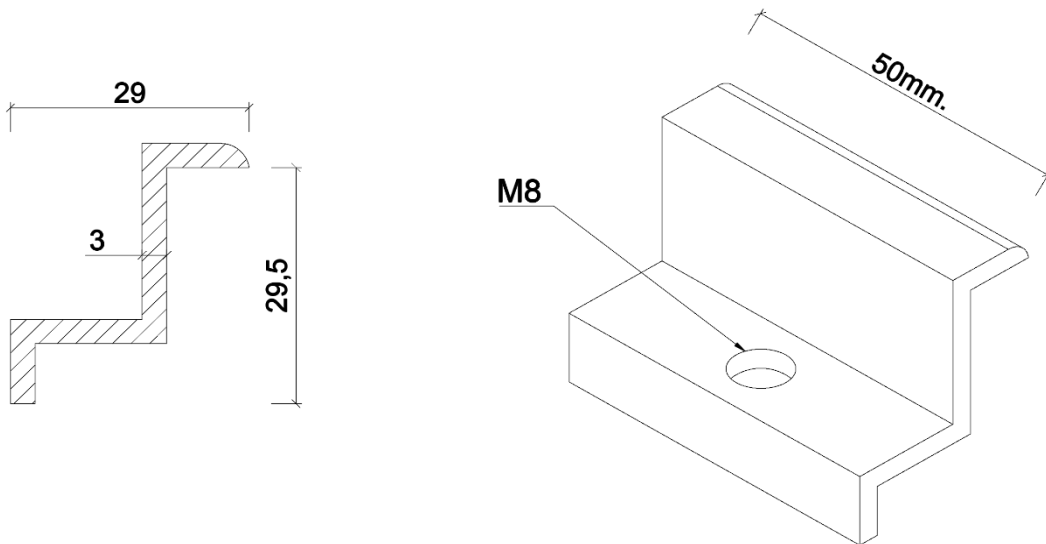

CERTIFIKATE OF CONFORMITY OF THE FACTORY PRODUCTION CONTROL  
2674-CPR-233541

In compliance with Regulation (EU) No 305/2011 of the European Parliament and of the Council of 9 March 2011 (the Construction products Regulation od CPR), this certificate applies to the construction products.

CONSTRUCTION PRODUCT(S)

Scope of certificate : Aluminium and aluminium alloys-Structural products for construction Works

EN 150088:2005

under system 2+ are applied that

the factory production control is assessed to be conformity with the applicable requirements.

This certificate was first issued on <20.12.2023> and will remain valid as long as neither the harmonised standard, the construction product, the AVCP methods nor the manufacturing conditions in the plant are modified significantly, unless suspended or withdrawn by FQC Standard Uygunluk Degerlendirme A. Ş. The validity of the document is ensured by annual audits.

- Dimension and Shape Tolerances -Yield Strength -Tensile Strength -Elongation	Product	General Condtions	Specific Condtions		Dimensions	Alloy
			Mechanical Specifinations	Tolarance		
	Extrude Profile	EN 755-1	EN 755-2	EN 755-9	Thickness min 0.9 mm. Thickness max. 20.0 mm.	EN AW 6060 EN AW 6063 EN AW 6463



# Technisches Datenblatt

## 231926 Erdungsklemme M8 Set

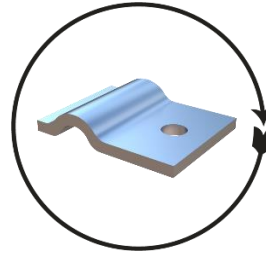
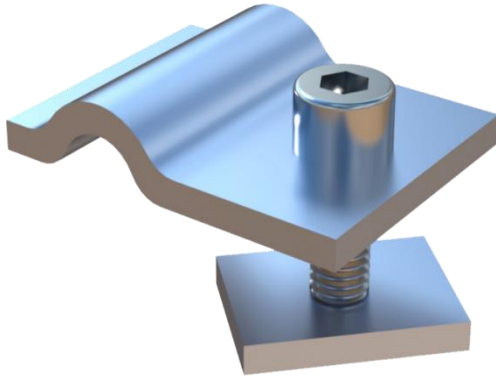

Erdungsklemme  
6063 T66

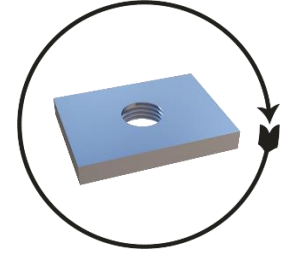

Aluverkantmutter  
6063 T66



Inbusschraube DIN 912 M8X20  
A2 Edelstahl

Art.Nr.	Bezeichnung	Material	Oberfläche	Stück/ Karton	Verpackung LXBXH	gr/ Stück
8601	Erdungsklemme M8 Set	EN AW 6063 T66	Blank	100	40 X 30 X 10	24,35
8602	Aluverkantmutter	EN AW 6063 T66	Blank	100		6,51
10102	Inbusschraube DIN 912 M8X20	A2	Edelstahl	100		14,24

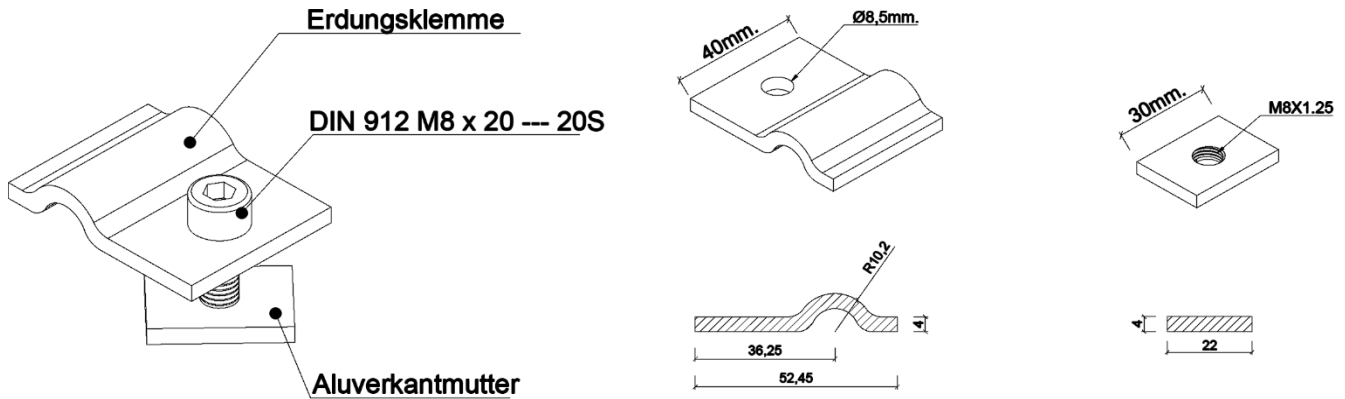

CERTIFIKATE OF CONFORMITY OF THE FACTORY PRODUCTION CONTROL  
2674-CPR-233541

In compliance with Regulation (EU) No 305/2011 of the European Parliament and of the Council of 9 March 2011 (the Construction products Regulation od CPR), this certificate applies to the construction products.

CONSTRUCTION PRODUCT(S)

Scope of certificate : Aluminium and aluminium alloys-Structural products for construction Works

EN 15008:2005

under system 2+ are applied that

the factory production control is assessed to be conformity with the applicable requirements.

This certificate was first issued on <20.12.2023> and will remain valid as long as neither the harmonised standard, the construction product, the AVCP methods nor the manufacturing conditions in the plant are modified significantly, unless suspended or withdrawn by FQC Standard Uygunluk Degerlendirme A. Ş. The validity of the document is ensured by annual audits.

- Dimension and Shape Tolerances -Yield Strength -Tensile Strength -Elongation	Product	General Conditions	Specific Conditions		Dimensions	Alloy
			Mechanical Specifications	Tolerance		
	Extrude Profile	EN 755-1	EN 755-2	EN 755-9	Thickness min 0.9 mm. Thickness max. 20.0 mm.	EN AW 6060 EN AW 6063 EN AW 6463



## 240181 Kreuzverbinder M12

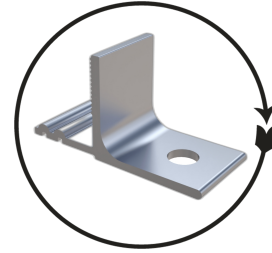
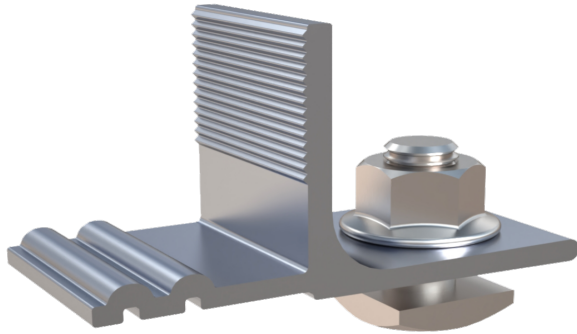

Kreuzverbinder (M12)  
6063 T66

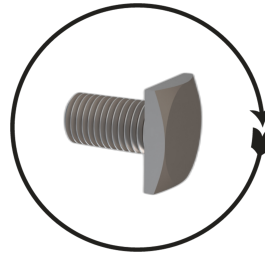

M12 Vierkantschraube  
A2 Edelstahl

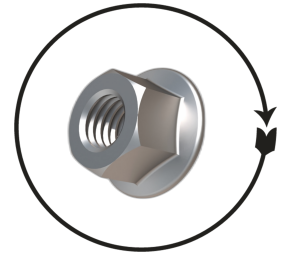

M12 Sechskantmutter mit Scheibe  
A2 Edelstahl

Art.Nr.	Bezeichnung	Material	Oberfläche	Stück/ Karton	Verpackung LXBXH	gr/ Stück
8255	Kreuzverbinder (M12)	EN AW 6063 T66	Blank	60	60 X 40 X 10	41,65
10200	M12 Vierkantschraube	A2	Edelstahl	60		41,98
10201	M12 Sechskantmutter mit Scheibe	A2	Edelstahl	60		12,69

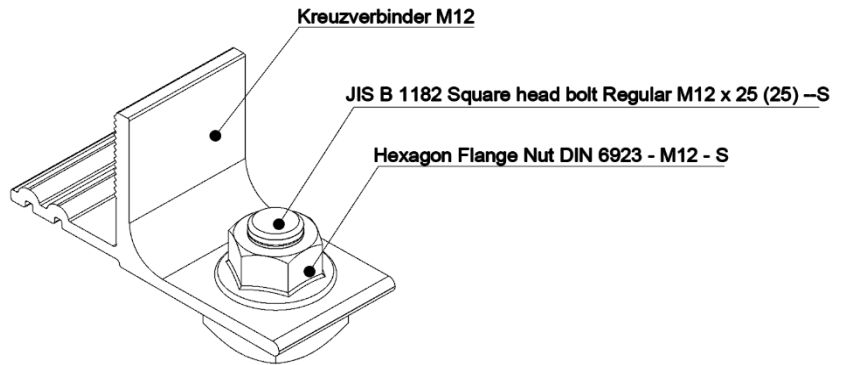
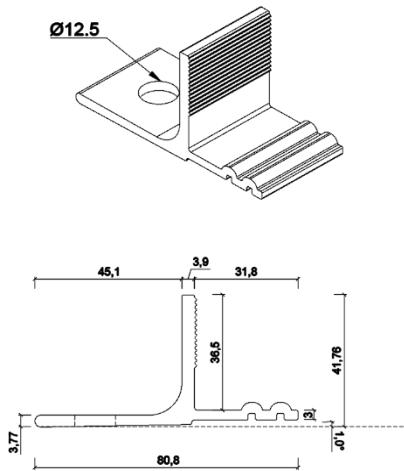

CERTIFICATE OF CONFORMITY OF THE FACTORY PRODUCTION CONTROL  
2674-CPR-233541

In compliance with Regulation (EU) No 305/2011 of the European Parliament and of the Council of 9 March 2011 (the Construction products Regulation od CPR), this certificate applies to the construction products.

CONSTRUCTION PRODUCT(S)

Scope of certificate : Aluminium and aluminium alloys-Structural products for construction Works

EN 150088:2005

under system 2+ are applied that

the factory production control is assessed to be conformity with the applicable requirements.

This certificate was first issued on <20.12.2023> and will remain valid as long as neither the harmonised standard, the construction product, the AVCP methods nor the manufacturing conditions in the plant are modified significantly, unless suspended or withdrawn by FQC Standard Uygunluk Degerlendirme A. Ş. The validity of the document is ensured by annual audits.

- Dimension and Shape Tolerances -Yield Strength -Tensile Strength -Elongation	Product	General Conditions	Specific Conditions		Dimensions	Alloy
			Mechanical Specifications	Tolerance		
	Extrude Profile	EN 755-1	EN 755-2	EN 755-9	Thickness min 0.9 mm. Thickness max. 20.0 mm.	EN AW 6060 EN AW 6063 EN AW 6463



## 811570 Verstell-Winkel B75

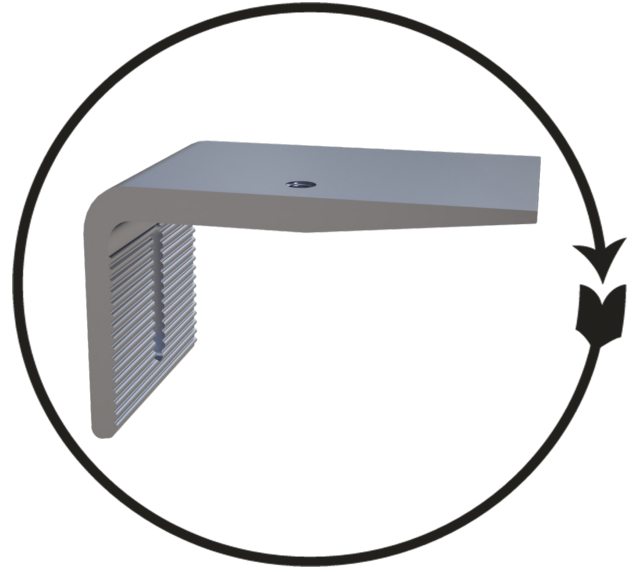
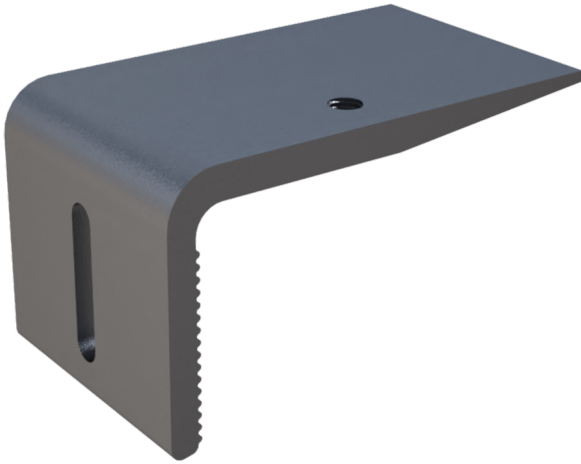

Verstell-Winkel B75  
6063 T66

Bezeichnung	Material	Oberfläche	Stück/ Karton	Verpackung LXBXH	gr/ Stück
Verstell-Winkel B75	EN AW 6063 T66	Blank	40	40 X 30 X 10	268,21

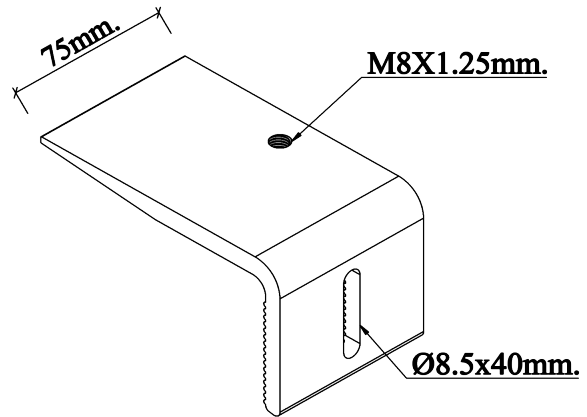
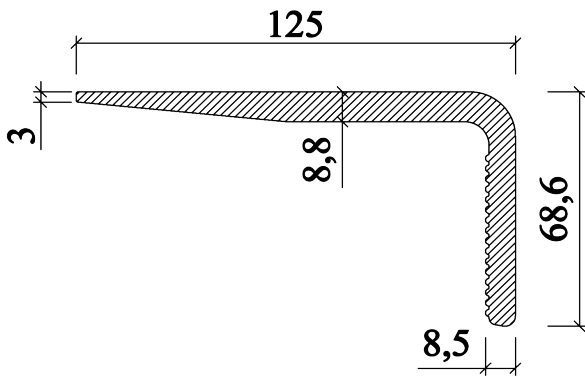

CERTIFIKATE OF CONFORMITY OF THE FACTORY PRODUCTION CONTROL  
2674-CPR-233541

In compliance with Regulation (EU) No 305/2011 of the European Parliament and of the Council of 9 March 2011 (the Construction products Regulation od CPR), this certificate applies to the construction products.

CONSTRUCTION PRODUCT(S)

Scope of certificate : Aluminium and aluminium alloys-Structural products for construction Works

EN 150088:2005

under system 2+ are applied that

the factory production control is assessed to be conformity with the applicable requirements.

This certificate was first issued on <20.12.2023> and will remain valid as long as neither the harmonised standard, the construction product, the AVCP methods nor the manufacturing conditions in the plant are modified significantly, unless suspended or withdrawn by FQC Standard Uygunluk Degerlendirme A. Ş. The validity of the document is ensured by annual audits.

- Dimension and Shape Tolerances -Yield Strength -Tensile Strength -Elongation	Product	General Condtions	Specific Condtions		Dimensions	Alloy
			Mechanical Specifications	Tolarance		
	Extrude Profile	EN 755-1	EN 755-2	EN 755-9	Thickness min 0.9 mm. Thickness max. 20.0 mm.	EN AW 6060 EN AW 6063 EN AW 6463





## 811571 Verstell-Winkel B75S

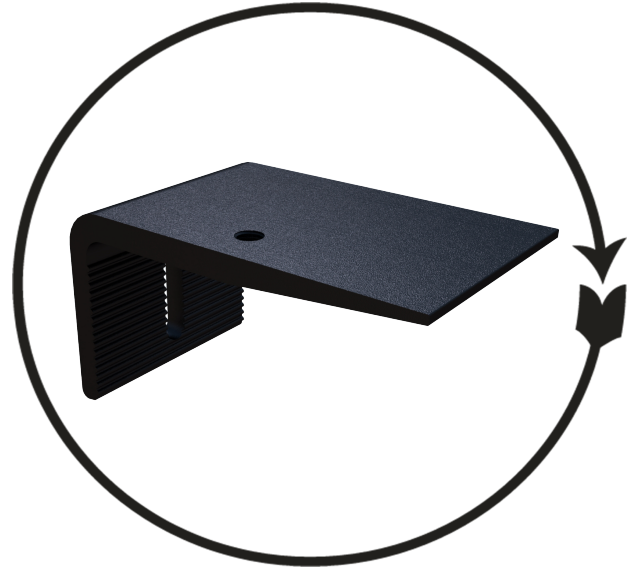
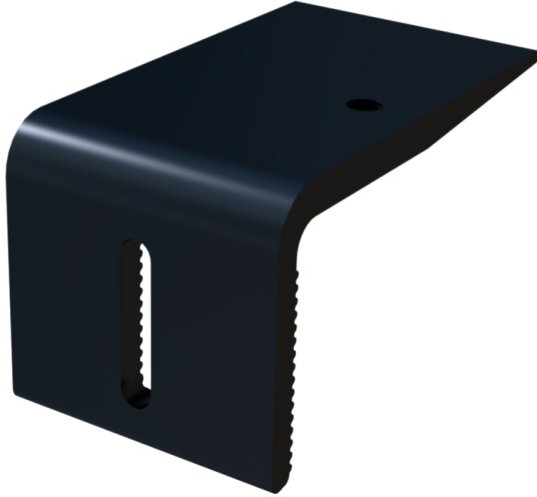

Verstell-Winkel B75  
6063 T66

Bezeichnung	Material	Oberfläche	Stück/ Karton	Verpackung LXBXH	gr/ Stück
Verstell-Winkel B75S	EN AW 6063 T66	Schwarz Eloxiert	40	40 X 30 X 10	268,21

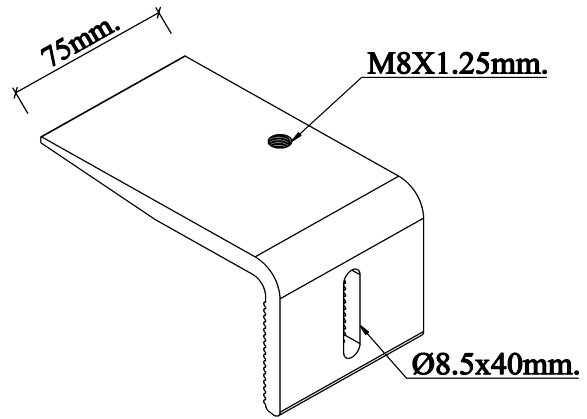
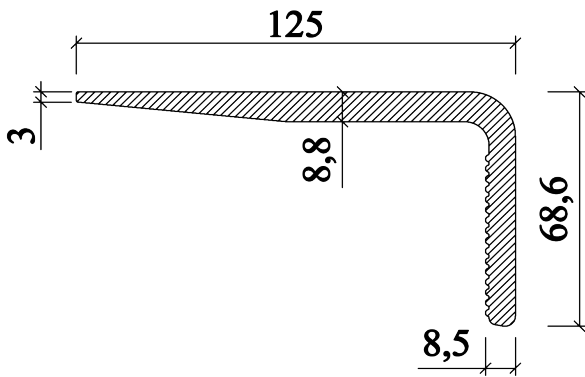

CERTIFIKATE OF CONFORMITY OF THE FACTORY PRODUCTION CONTROL  
2674-CPR-233541

In compliance with Regulation (EU) No 305/2011 of the European Parliament and of the Council of 9 March 2011 (the Construction products Regulation od CPR), this certificate applies to the construction products.

CONSTRUCTION PRODUCT(S)

Scope of certificate : Aluminium and aluminium alloys-Structural products for construction Works

EN 150088:2005

under system 2+ are applied that

the factory production control is assessed to be conformity with the applicable requirements.

This certificate was first issued on <20.12.2023> and will remain valid as long as neither the harmonised standard, the construction product, the AVCP methods nor the manufacturing conditions in the plant are modified significantly, unless suspended or withdrawn by FQC Standard Uygunluk Degerlendirme A. Ş. The validity of the document is ensured by annual audits.

- Dimension and Shape Tolerances -Yield Strength -Tensile Strength -Elongation	Product	General Conductions	Specific Conditions		Dimensions	Alloy
			Mechanical Specifications	Tolarance		
	Extrude Profile	EN 755-1	EN 755-2	EN 755-9	Thickness min 0.9 mm. Thickness max. 20.0 mm.	EN AW 6060 EN AW 6063 EN AW 6463



## 825035 Endklemme Blank Z Form 35 mm

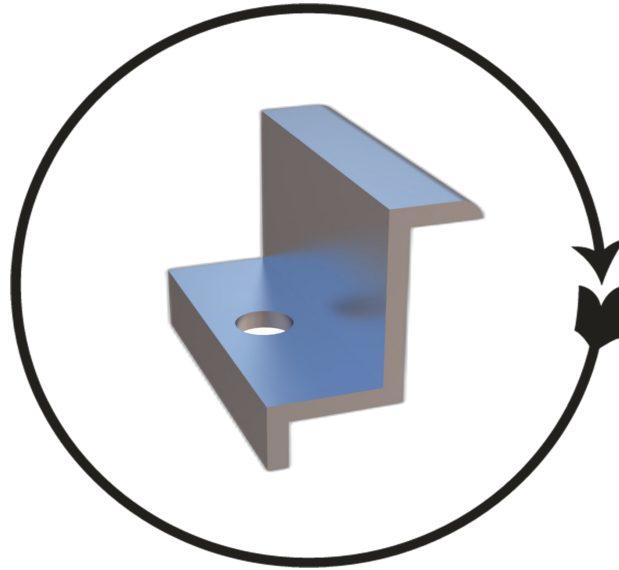

Endklemme Z Form 35  
6063 T66

Bezeichnung	Material	Oberfläche	Stück/ Karton	Verpackung LXBXH	gr/ Stück
Endklemme Blank Z Form 35 mm	EN AW 6063 T66	Blank	100	40 X 30 X 10	29,98

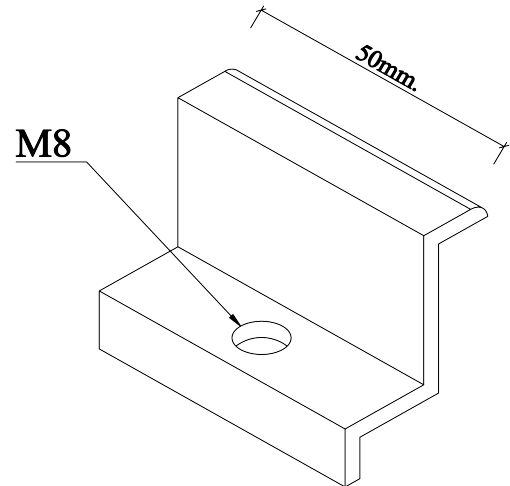
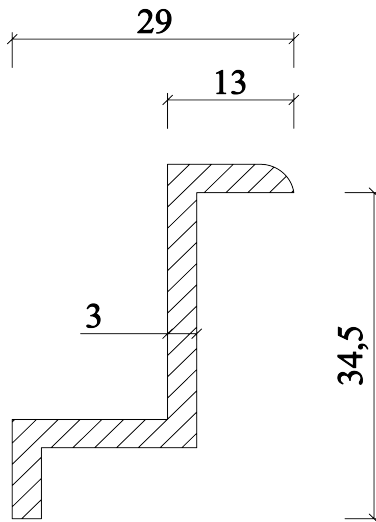

CERTIFIKATE OF CONFORMITY OF THE FACTORY PRODUCTION CONTROL  
2674-CPR-233541

In compliance with Regulation (EU) No 305/2011 of the European Parliament and of the Council of 9 March 2011 (the Construction products Regulation od CPR), this certificate applies to the construction products.

CONSTRUCTION PRODUCT(S)

Scope of certificate : Aluminium and aluminium alloys-Structural products for construction Works

EN 150088:2005

under system 2+ are applied that

the factory production control is assessed to be conformity with the applicable requirements.

This certificate was first issued on <20.12.2023> and will remain valid as long as neither the harmonised standard, the construction product, the AVCP methods nor the manufacturing conditions in the plant are modified significantly, unless suspended or withdrawn by FQC Standard Uygunluk Degerlendirme A. Ş. The validity of the document is ensured by annual audits.

- Dimension and Shape Tolerances -Yield Strength -Tensile Strength -Elongation	Product	General Conditions	Specific Conditions		Dimensions	Alloy
			Mechanical Specifications	Tolerance		
	Extrude Profile	EN 755-1	EN 755-2	EN 755-9	Thickness min 0.9 mm. Thickness max. 20.0 mm.	EN AW 6060 EN AW 6063 EN AW 6463



# 825036 Endklemme Schwarz Eloxiert Z Form 30 mm

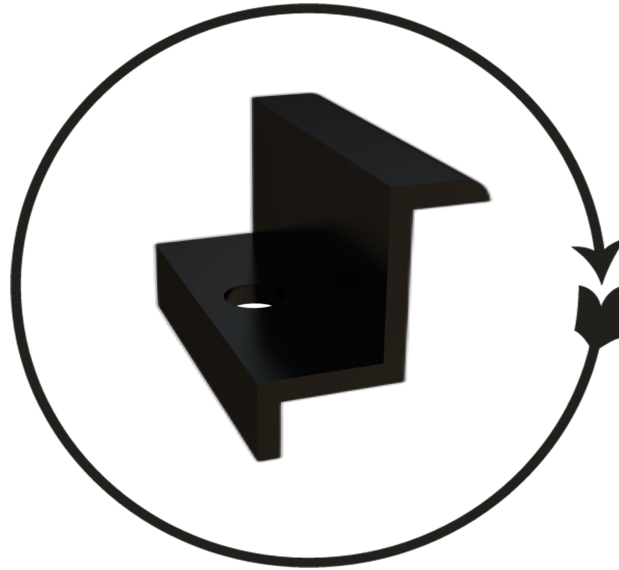

Endklemme Schwarz Eloxiert Z Form  
6063 T66

Bezeichnung	Material	Oberfläche	Stück/ Karton	Verpackung LXBXH	gr/ Stück
Endklemme Schwarz Eloxiert Z Form 30 mm	EN AW 6063 T66	Schwarz Eloxiert	100	40 X 30 X 10	27,15

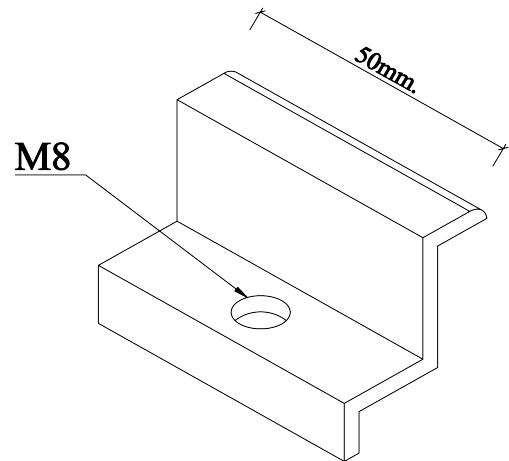
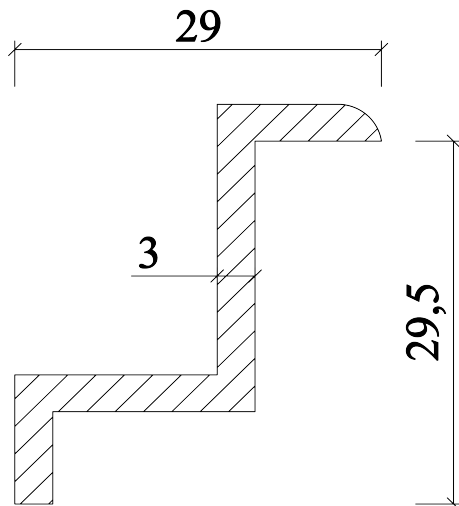

CERTIFIKATE OF CONFORMITY OF THE FACTORY PRODUCTION CONTROL  
2674-CPR-233541

In compliance with Regulation (EU) No 305/2011 of the European Parliament and of the Council of 9 March 2011 (the Construction products Regulation od CPR), this certificate applies to the construction products.

CONSTRUCTION PRODUCT(S)

Scope of certificate : Aluminium and aluminium alloys-Structural products for construction Works

EN 150088:2005

under system 2+ are applied that

the factory production control is assessed to be conformity with the applicable requirements.

This certificate was first issued on <20.12.2023> and will remain valid as long as neither the harmonised standard, the construction product, the AVCP methods nor the manufacturing conditions in the plant are modified significantly, unless suspended or withdrawn by FQC Standard Uygunluk Degerlendirme A. Ş. The validity of the document is ensured by annual audits.

- Dimension and Shape Tolerances -Yield Strength -Tensile Strength -Elongation	Product	General Conditions	Specific Conditions		Dimensions	Alloy
			Mechanical Specifications	Tolerance		
	Extrude Profile	EN 755-1	EN 755-2	EN 755-9	Thickness min 0.9 mm. Thickness max. 20.0 mm.	EN AW 6060 EN AW 6063 EN AW 6463



# 825037 Endklemme Schwarz Eloxiert Z- Form 35 mm

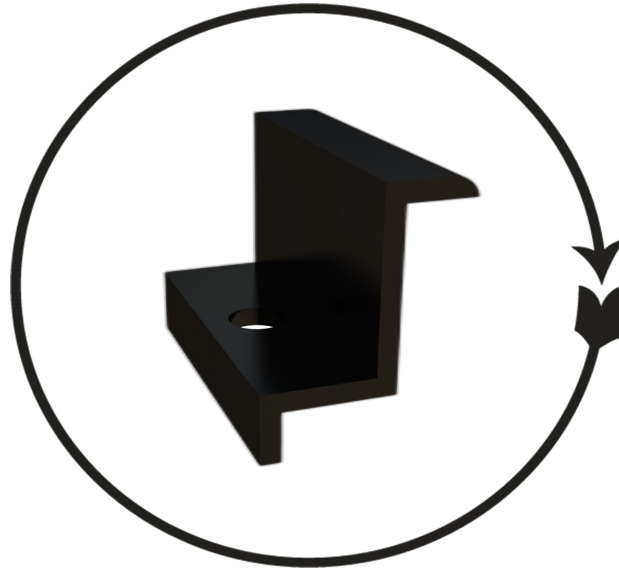

Endklemme Schwarz Eloxiert Z Form 35  
6063 T66

Bezeichnung	Material	Oberfläche	Stück/ Karton	Verpackung LXBXH	gr/ Stück
Endklemme Schwarz Eloxiert Z-Form 35 mm	EN AW 6063 T66	Schwarz Eloxiert	100	40 X 30 X 10	29,98

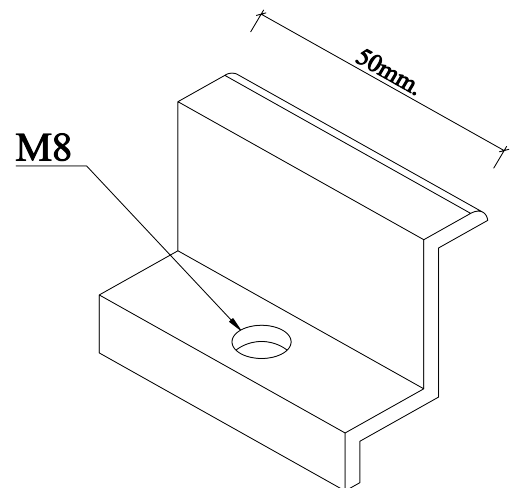
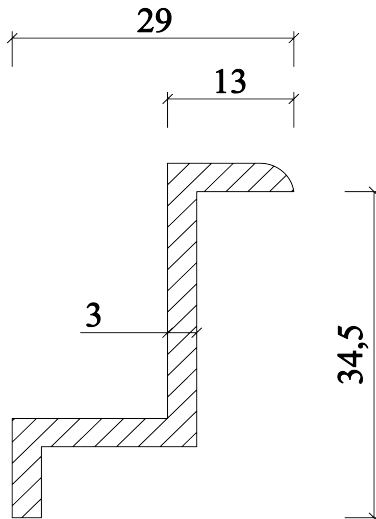

CERTIFIKATE OF CONFORMITY OF THE FACTORY PRODUCTION CONTROL  
2674-CPR-233541

In compliance with Regulation (EU) No 305/2011 of the European Parliament and of the Council of 9 March 2011 (the Construction products Regulation od CPR), this certificate applies to the construction products.

CONSTRUCTION PRODUCT(S)

Scope of certificate : Aluminium and aluminium alloys-Structural products for construction Works

EN 150088:2005

under system 2+ are applied that

the factory production control is assessed to be conformity with the applicable requirements.

This certificate was first issued on <20.12.2023> and will remain valid as long as neither the harmonised standard, the construction product, the AVCP methods nor the manufacturing conditions in the plant are modified significantly, unless suspended or withdrawn by FQC Standard Uygunluk Degerlendirme A. Ş. The validity of the document is ensured by annual audits.

- Dimension and Shape Tolerances -Yield Strength -Tensile Strength -Elongation	Product	General Condtions	Specific Condtions		Dimensions	Alloy
			Mechanical Specifications	Tolarance		
	Extrude Profile	EN 755-1	EN 755-2	EN 755-9	Thickness min 0.9 mm. Thickness max. 20.0 mm.	EN AW 6060 EN AW 6063 EN AW 6463



# Technisches Datenblatt

## 1923815 Abdeckkappen Schwarz für Montageprofil 4740 Set

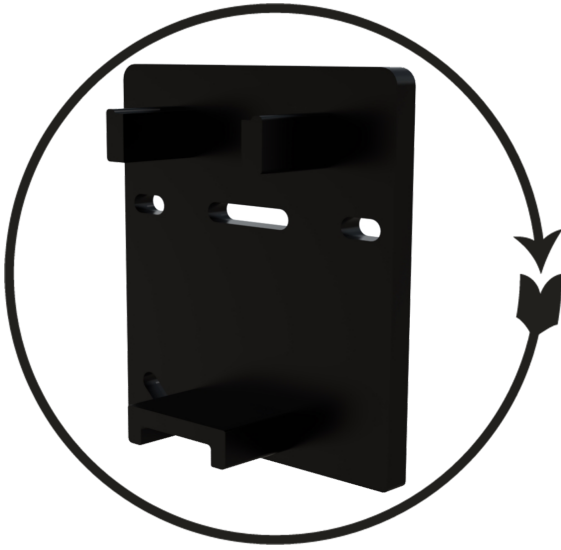

Abdeckkappe für P 4740 Links

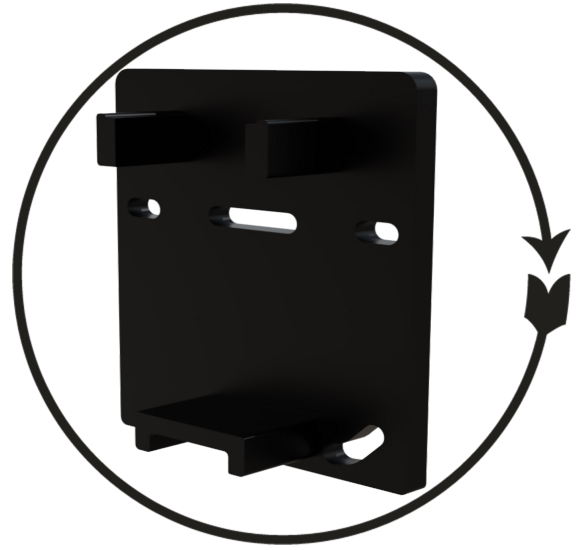

Abdeckkappe für P 4740 Rechts

Bezeichnung	Material	Oberfläche	Stück/ Karton	Verpackung LXBXH	gr/ Stück
Abdeckkappen Set ( L+R )	Kunststoff	Schwarz Mat	100 Set	40 X 30 X 10	7,95

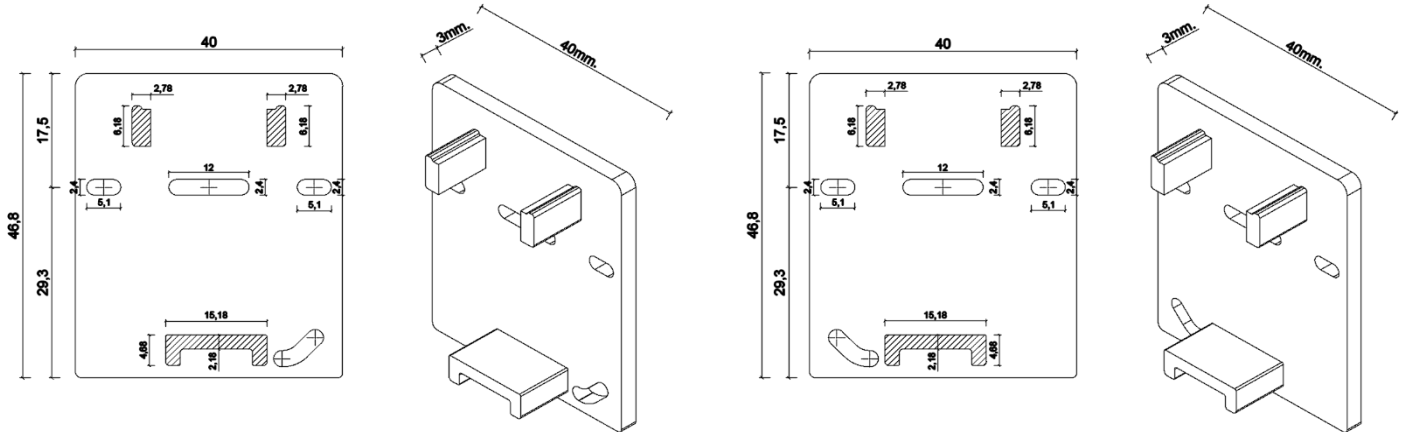

CERTIFIKATE OF CONFORMITY OF THE FACTORY PRODUCTION CONTROL  
2674-CPR-233541

In compliance with Regulation (EU) No 305/2011 of the European Parliament and of the Council of 9 March 2011 (the Construction products Regulation od CPR), this certificate applies to the construction products.

CONSTRUCTION PRODUCT(S)

Scope of certificate : Aluminium and aluminium alloys-Structural products for construction Works

EN 150088:2005

under system 2+ are applied that

the factory production control is assessed to be conformity with the applicable requirements.

This certificate was first issued on <20.12.2023> and will remain valid as long as neither the harmonised standard, the construction product, the AVCP methods nor the manufacturing conditions in the plant are modified significantly, unless suspended or withdrawn by FQC Standard Uygunluk Degerlendirme A. Ş. The validity of the document is ensured by annual audits.

- Dimension and Shape Tolerances -Yield Strength -Tensile Strength -Elongation	Product	General Conditions	Specific Conditions		Dimensions	Alloy
			Mechanical Specifications	Tolerance		
	Extrude Profile	EN 755-1	EN 755-2	EN 755-9	Thickness min 0.9 mm. Thickness max. 20.0 mm.	EN AW 6060 EN AW 6063 EN AW 6463



## 1923816 Abdeckkappen Grau für Montageprofil 4740 Set

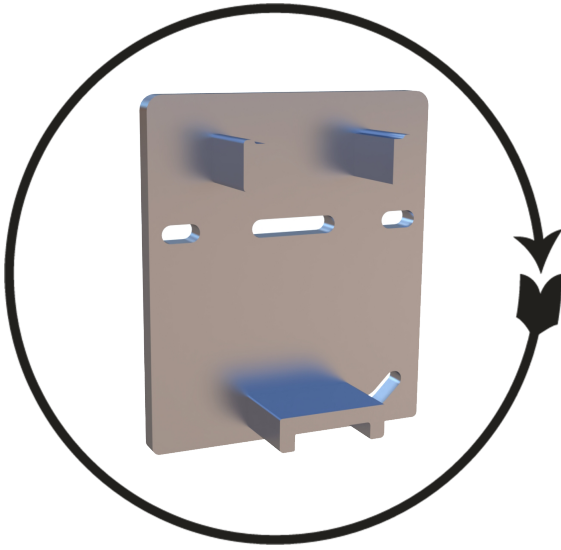

Abdeckkappe für P 4740 Links

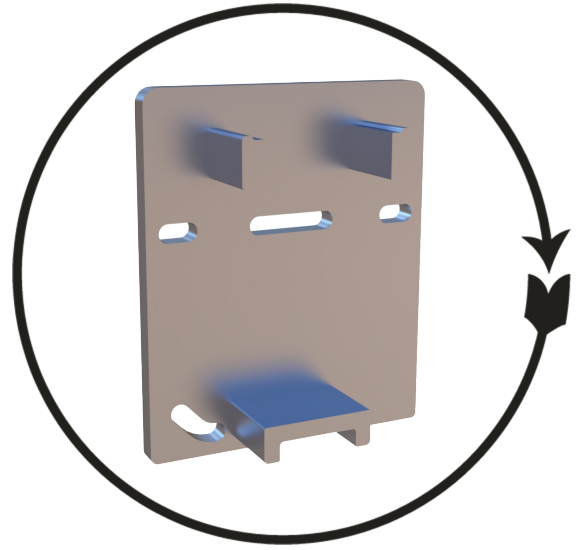

Abdeckkappe für P 4740 Rechts

Bezeichnung	Material	Oberfläche	Stück/ Karton	Verpackung LXBXH	gr/ Stück
Abdeckkappen Set ( L+R )	Kunststoff	Grau	100 Set	40 X 30 X 10	7,95

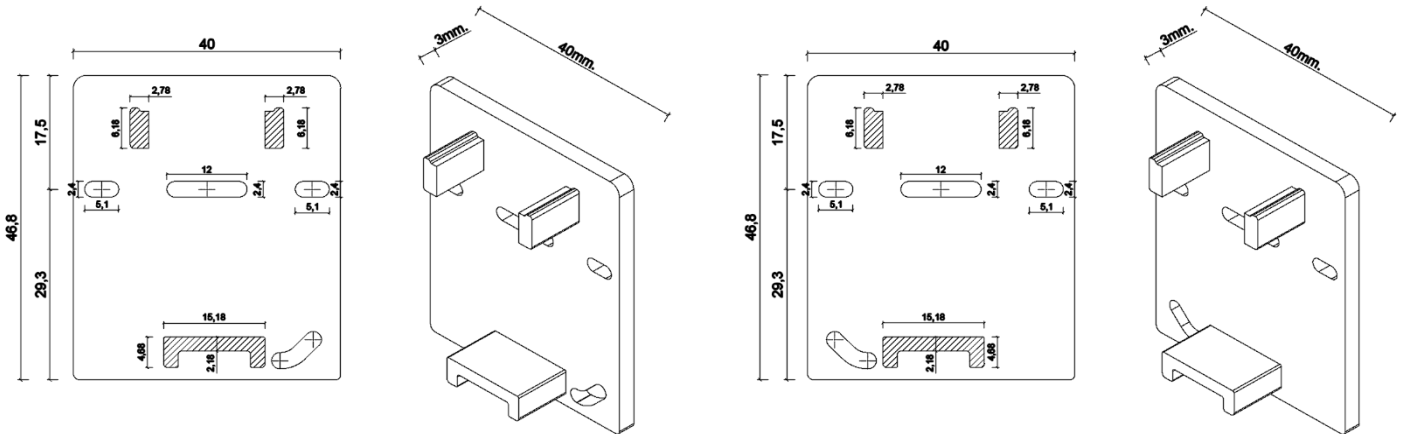

CERTIFIKATE OF CONFORMITY OF THE FACTORY PRODUCTION CONTROL  
2674-CPR-233541

In compliance with Regulation (EU) No 305/2011 of the European Parliament and of the Council of 9 March 2011 (the Construction products Regulation od CPR), this certificate applies to the construction products.

CONSTRUCTION PRODUCT(S)

Scope of certificate : Aluminium and aluminium alloys-Structural products for construction Works

EN 150088:2005

under system 2+ are applied that

the factory production control is assessed to be conformity with the applicable requirements.

This certificate was first issued on <20.12.2023> and will remain valid as long as neither the harmonised standard, the construction product, the AVCP methods nor the manufacturing conditions in the plant are modified significantly, unless suspended or withdrawn by FQC Standard Uygunluk Degerlendirme A. Ş. The validity of the document is ensured by annual audits.

- Dimension and Shape Tolerances -Yield Strength -Tensile Strength -Elongation	Product	General Conditions	Specific Conditions		Dimensions	Alloy
			Mechanical Specifications	Tolerance		
	Extrude Profile	EN 755-1	EN 755-2	EN 755-9	Thickness min 0.9 mm. Thickness max. 20.0 mm.	EN AW 6060 EN AW 6063 EN AW 6463



## 2023105 Alu-Gewindemuffe M32 für 2023106

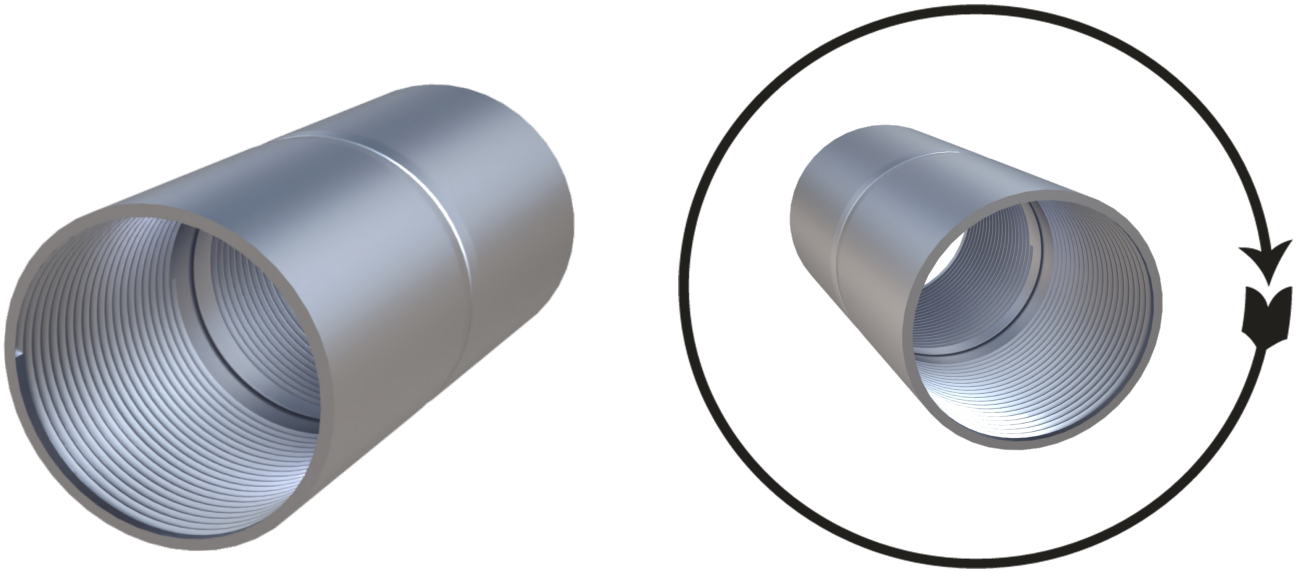

Alu-Gewindemuffe M32  
6063 T66

Bezeichnung	Material	Oberfläche	Stück/ Karton	Verpackung LXBXH	gr/ Stück
Gewindemuffe für Steckrohr $\varnothing$ 34,7 mm mit Beidseitigem Gewinde	EN AW 6063 T66	Blank	480	40 X 30 X 10	18,01

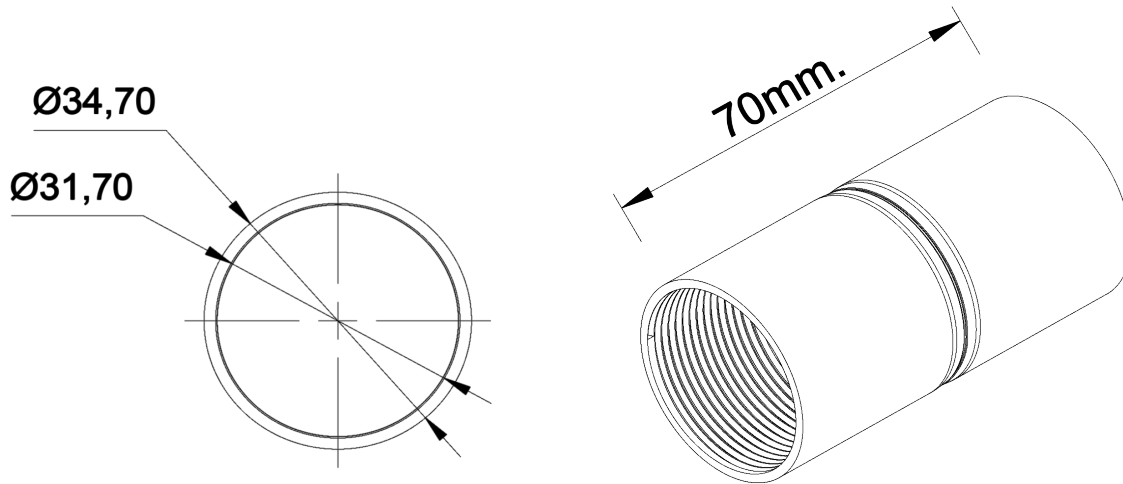

CERTIFIKATE OF CONFORMITY OF THE FACTORY PRODUCTION CONTROL  
2674-CPR-233541

In compliance with Regulation (EU) No 305/2011 of the European Parliament and of the Council of 9 March 2011 (the Construction products Regulation od CPR), this certificate applies to the construction products.

CONSTRUCTION PRODUCT(S)

Scope of certificate : Aluminium and aluminium alloys-Structural products for construction Works

EN 150088:2005

under system 2+ are applied that

the factory production control is assessed to be conformity with the applicable requirements.

This certificate was first issued on <20.12.2023> and will remain valid as long as neither the harmonised standard, the construction product, the AVCP methods nor the manufacturing conditions in the plant are modified significantly, unless suspended or withdrawn by FQC Standard Uygunluk Degerlendirme A. Ş. The validity of the document is ensured by annual audits.

- Dimension and Shape Tolerances -Yield Strength -Tensile Strength -Elongation	Product	General Conditions	Specific Conditions		Dimensions	Alloy
			Mechanical Specifications	Tolerance		
	Extrude Profile	EN 755-1	EN 755-2	EN 755-9	Thickness min 0.9 mm. Thickness max. 20.0 mm.	EN AW 6060 EN AW 6063 EN AW 6463



# Technisches Datenblatt

## 2023105/1 Alu-Steckmuffe M32 für Alu Steckrohr 2023106/1

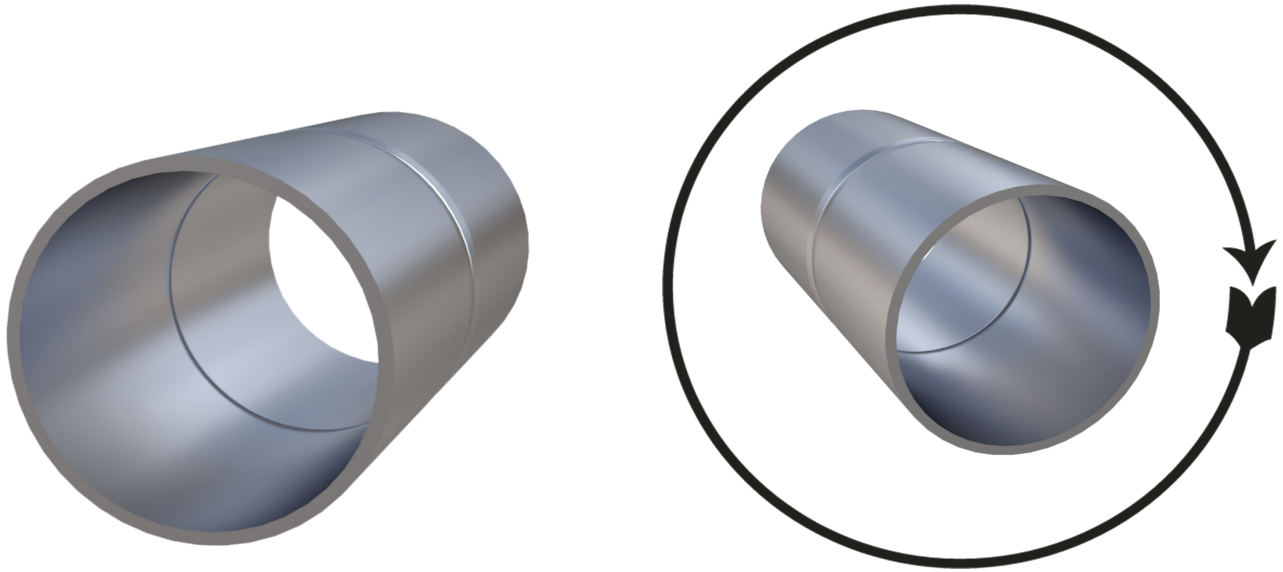

Alu-Steckmuffe M32  
6063 T66

Bezeichnung	Material	Oberfläche	Stück/ Karton	Verpackung LXBXH	gr/ Stück
2023105/1 Alu Stuckmuffe für Steckrohr ø 34,7 mm ohn Gewinde	EN AW 6063 T66	Blank	480	40 X 30 X 10	25,63

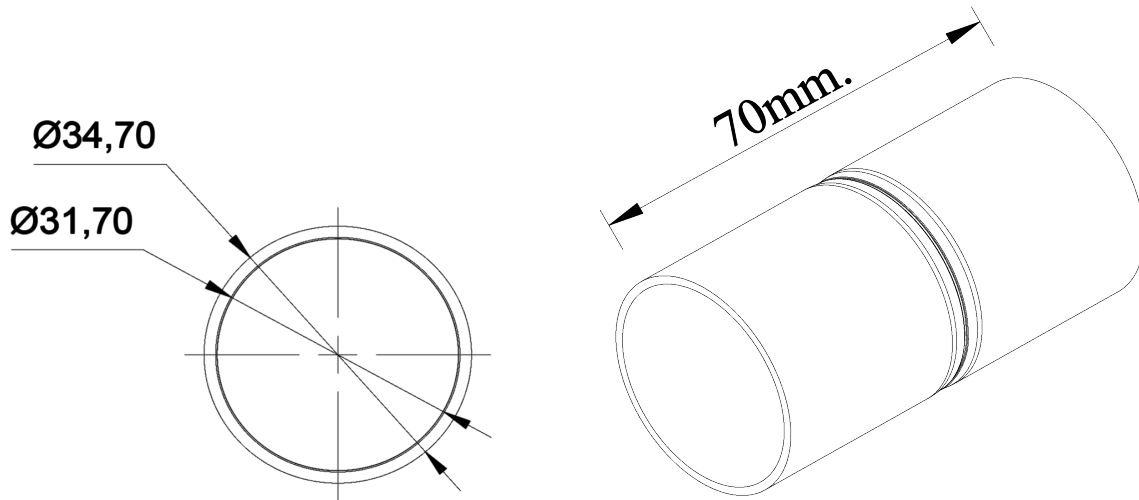

CERTIFIKATE OF CONFORMITY OF THE FACTORY PRODUCTION CONTROL  
2674-CPR-233541

In compliance with Regulation (EU) No 305/2011 of the European Parliament and of the Council of 9 March 2011 (the Construction products Regulation od CPR), this certificate applies to the construction products.

CONSTRUCTION PRODUCT(S)

Scope of certificate : Aluminium and aluminium alloys-Structural products for construction Works

EN 150088:2005

under system 2+ are applied that

the factory production control is assessed to be conformity with the applicable requirements.

This certificate was first issued on <20.12.2023> and will remain valid as long as neither the harmonised standard, the construction product, the AVCP methods nor the manufacturing conditions in the plant are modified significantly, unless suspended or withdrawn by FQC Standard Uygunluk Degerlendirme A. Ş. The validity of the document is ensured by annual audits.

- Dimension and Shape Tolerances -Yield Strength -Tensile Strength -Elongation	Product	General Conditions	Specific Conditions		Dimensions	Alloy
			Mechanical Specifications	Tolerance		
	Extrude Profile	EN 755-1	EN 755-2	EN 755-9	Thickness min 0.9 mm. Thickness max. 20.0 mm.	EN AW 6060 EN AW 6063 EN AW 6463





# Technisches Datenblatt

## 2023106/1 Alu-Gewinderohr ø31,8 mm ( L= 2500 mm )

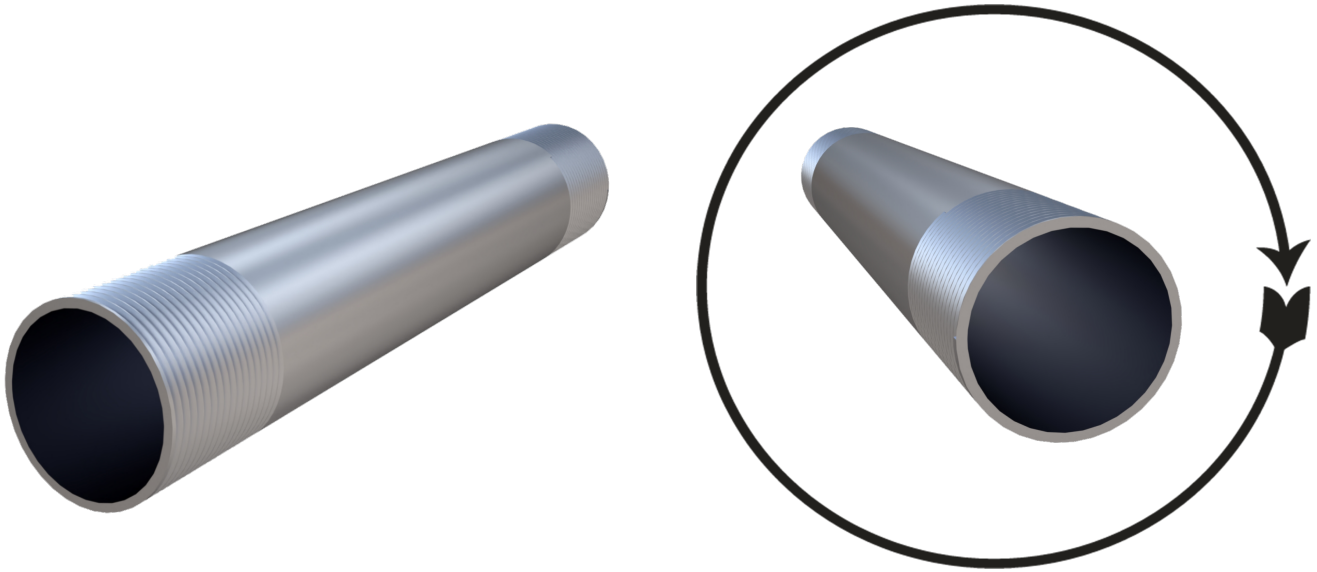

Alu-Gewinderohr L= 2500 mm  
6063 T66

Bezeichnung	Material	Oberfläche	Stück/ Karton	Verpackung LXBXH	kg/ Stück
Dc Kabelkanal Gewinderohr ø 31,8 mm mit Beidseitigem Gewinde 2,50 m	EN AW 6063 T66	Blank	480	40 X 30 X 10	0,956

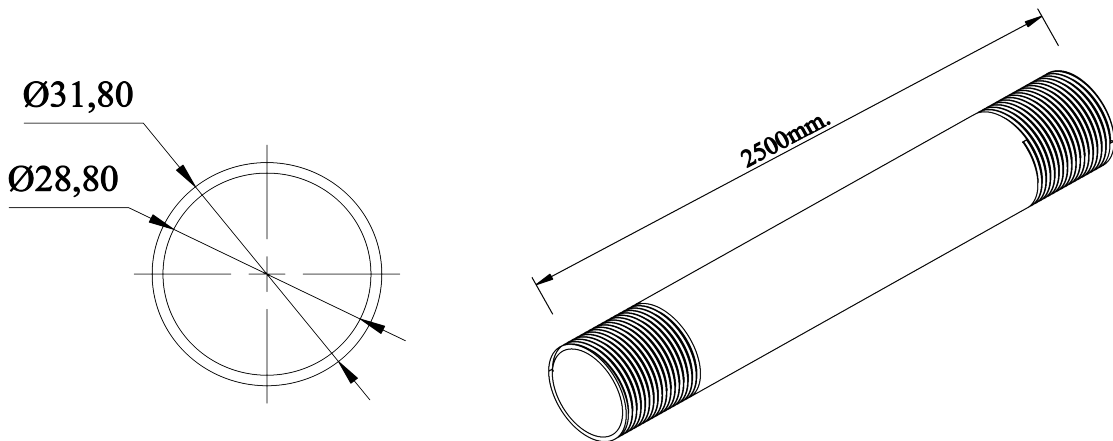

CERTIFIKATE OF CONFORMITY OF THE FACTORY PRODUCTION CONTROL  
2674-CPR-233541

In compliance with Regulation (EU) No 305/2011 of the European Parliament and of the Council of 9 March 2011 (the Construction products Regulation od CPR), this certificate applies to the construction products.

CONSTRUCTION PRODUCT(S)

Scope of certificate : Aluminium and aluminium alloys-Structural products for construction Works

EN 150088:2005

under system 2+ are applied that

the factory production control is assessed to be conformity with the applicable requirements.

This certificate was first issued on <20.12.2023> and will remain valid as long as neither the harmonised standard, the construction product, the AVCP methods nor the manufacturing conditions in the plant are modified significantly, unless suspended or withdrawn by FQC Standard Uygunluk Degerlendirme A. Ş. The validity of the document is ensured by annual audits.

- Dimension and Shape Tolerances -Yield Strength -Tensile Strength -Elongation	Product	General Conditions	Specific Conditions		Dimensions	Alloy
			Mechanical Specifications	Tolerance		
	Extrude Profile	EN 755-1	EN 755-2	EN 755-9	Thickness min 0.9 mm. Thickness max. 20.0 mm.	EN AW 6060 EN AW 6063 EN AW 6463



# Technisches Datenblatt

## 2023106 Alu-Rohr ø31,8 mm ( L= 2500 mm )

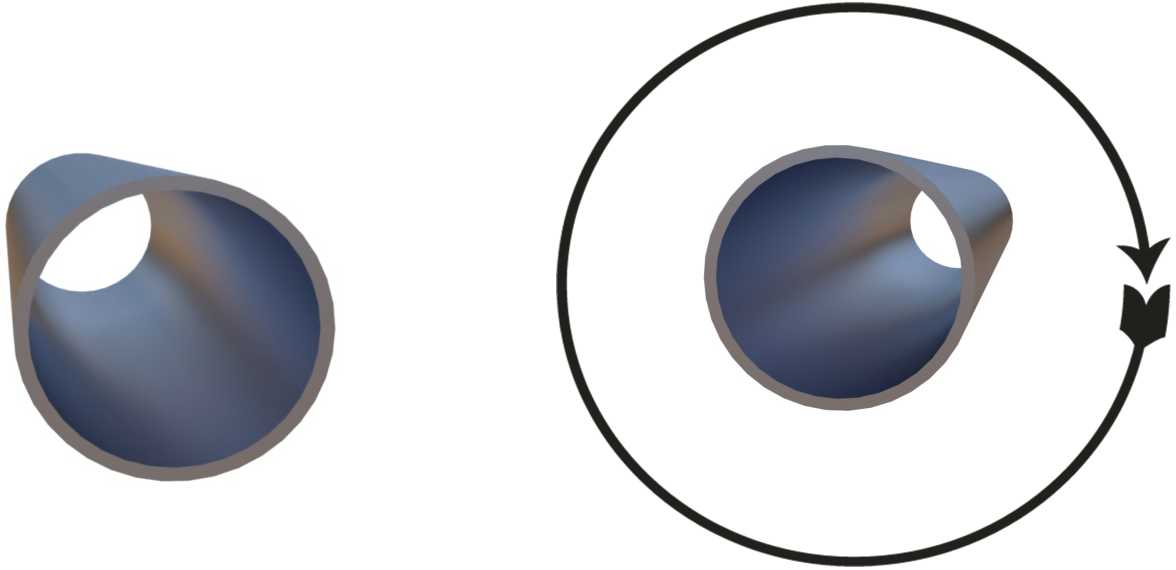

Alu Rohr L= 2500 mm  
6063 T66

Bezeichnung	Material	Oberfläche	Stück/ Karton	Verpackung LXBXH	kg/ Stück
Alu-Rohr ø31,8 mm ( L= 2500 mm )	EN AW 6063 T66	Blank	480	40 X 30 X 10	0,956

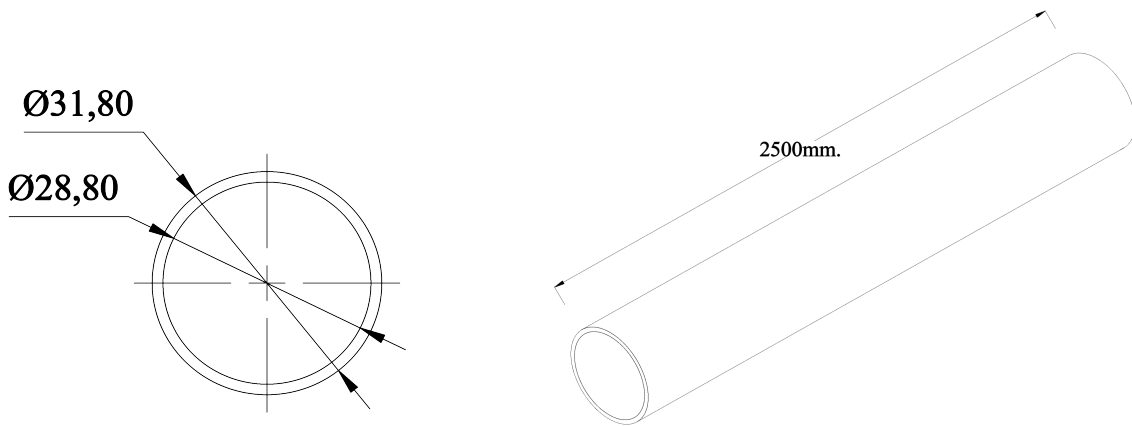

CERTIFIKATE OF CONFORMITY OF THE FACTORY PRODUCTION CONTROL  
2674-CPR-233541

In compliance with Regulation (EU) No 305/2011 of the European Parliament and of the Council of 9 March 2011 (the Construction products Regulation od CPR), this certificate applies to the construction products.

CONSTRUCTION PRODUCT(S)

Scope of certificate : Aluminium and aluminium alloys-Structural products for construction Works

EN 150088:2005

under system 2+ are applied that

the factory production control is assessed to be conformity with the applicable requirements.

This certificate was first issued on <20.12.2023> and will remain valid as long as neither the harmonised standard, the construction product, the AVCP methods nor the manufacturing conditions in the plant are modified significantly, unless suspended or withdrawn by FQC Standard Uygunluk Degerlendirme A. Ş. The validity of the document is ensured by annual audits.

- Dimension and Shape Tolerances -Yield Strength -Tensile Strength -Elongation	Product	General Conditions	Specific Conditions		Dimensions	Alloy
			Mechanical Specifications	Tolerance		
	Extrude Profile	EN 755-1	EN 755-2	EN 755-9	Thickness min 0.9 mm. Thickness max. 20.0 mm.	EN AW 6060 EN AW 6063 EN AW 6463



## 2023107 Alu-Klemmschelle M32 für Alusteckrohr 2023106/1

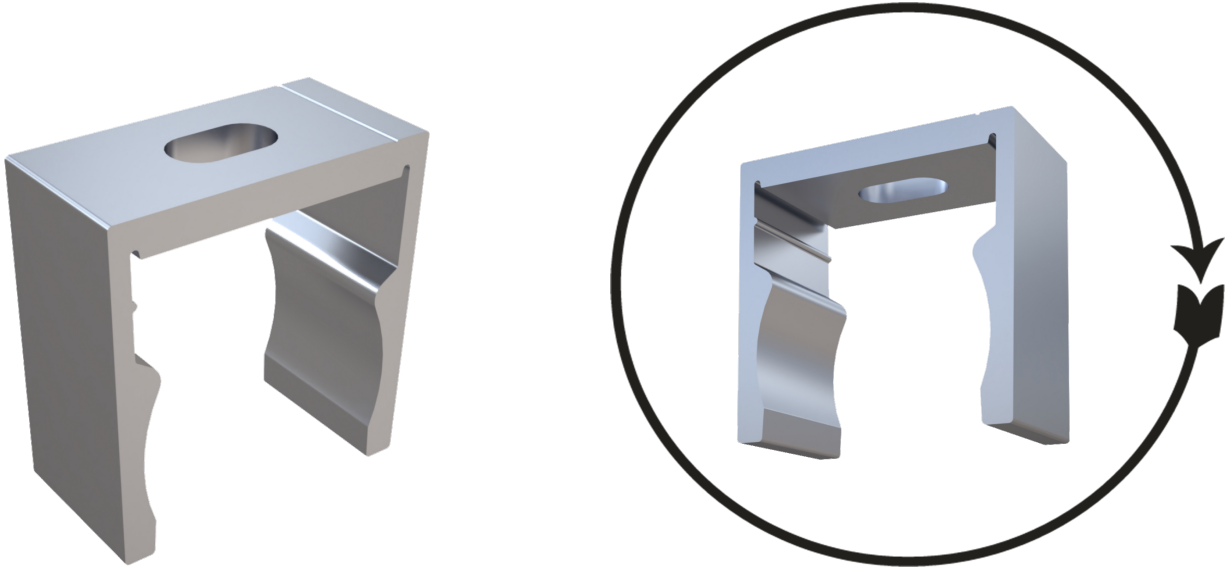

Alu-Klemmschelle M32  
6063 T66

Bezeichnung	Material	Oberfläche	Stück/ Karton	Verpackung LXBXH	gr/ Stück
Alu-Klemmschelle ø 34,7mm	EN AW 6063 T66	Blank	480	40 X 30 X 10	15,97

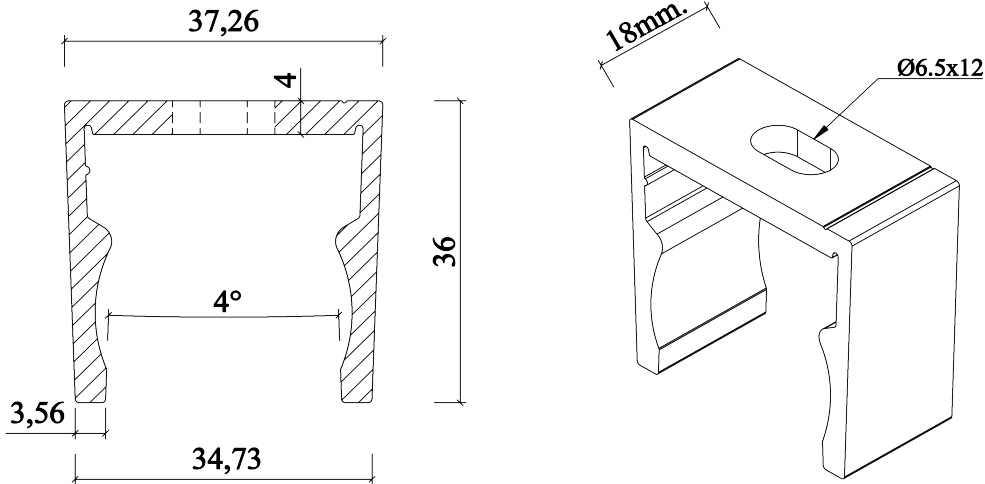

CERTIFIKATE OF CONFORMITY OF THE FACTORY PRODUCTION CONTROL  
2674-CPR-233541

In compliance with Regulation (EU) No 305/2011 of the European Parliament and of the Council of 9 March 2011 (the Construction products Regulation od CPR), this certificate applies to the construction products.

CONSTRUCTION PRODUCT(S)

Scope of certificate : Aluminium and aluminium alloys-Structural products for construction Works

EN 150088:2005

under system 2+ are applied that

the factory production control is assessed to be conformity with the applicable requirements.

This certificate was first issued on <20.12.2023> and will remain valid as long as neither the harmonised standard, the construction product, the AVCP methods nor the manufacturing conditions in the plant are modified significantly, unless suspended or withdrawn by FQC Standard Uygunluk Degerlendirme A. Ş. The validity of the document is ensured by annual audits.

- Dimension and Shape Tolerances -Yield Strength -Tensile Strength -Elongation	Product	General Conditions	Specific Conditions		Dimensions	Alloy
			Mechanical Specifications	Tolerance		
	Extrude Profile	EN 755-1	EN 755-2	EN 755-9	Thickness min 0.9 mm. Thickness max. 20.0 mm.	EN AW 6060 EN AW 6063 EN AW 6463



## 19234300 Montage Winkel für Profil 4740

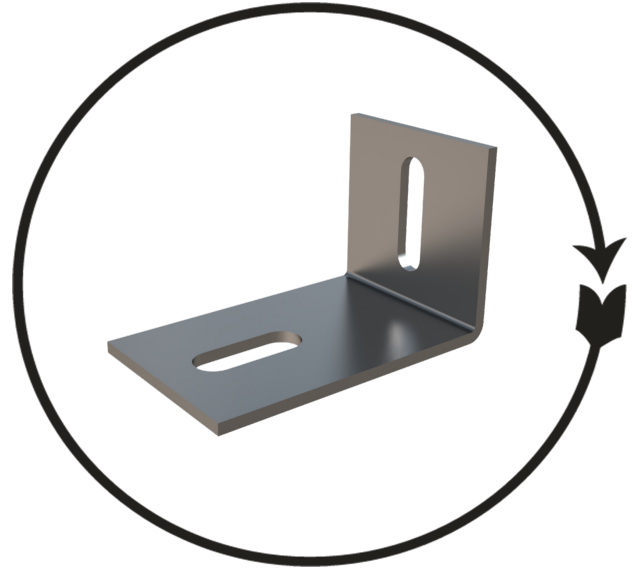
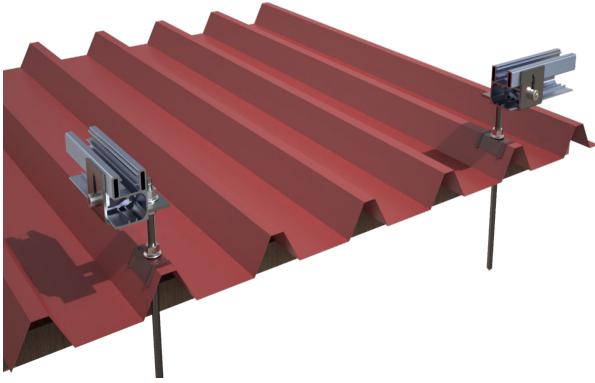

L- Winkel P4740  
*Edelstahl*

Bezeichnung	Material	Oberfläche	Stück/ Karton	Verpackung LXBXH	gr/ Stück
L-Winkel P4740	A2	Edelstahl	75	40 X 30 X 10	131,72

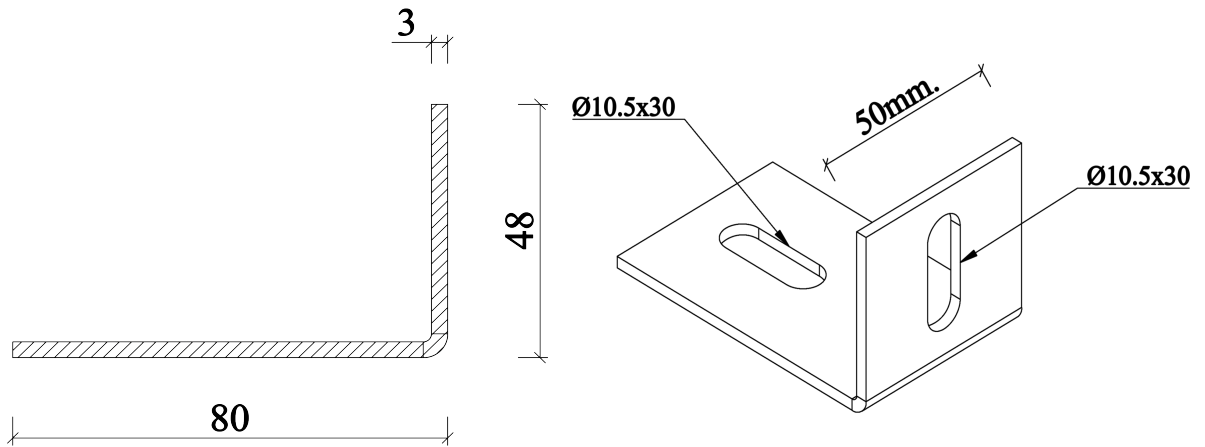

CERTIFIKATE OF CONFORMITY OF THE FACTORY PRODUCTION CONTROL  
2674-CPR-233541

In compliance with Regulation (EU) No 305/2011 of the European Parliament and of the Council of 9 March 2011 (the Construction products Regulation od CPR), this certificate applies to the construction products.

CONSTRUCTION PRODUCT(S)

Scope of certificate : Aluminium and aluminium alloys-Structural products for construction Works

EN 150088:2005

under system 2+ are applied that

the factory production control is assessed to be conformity with the applicable requirements.

This certificate was first issued on <20.12.2023> and will remain valid as long as neither the harmonised standard, the construction product, the AVCP methods nor the manufacturing conditions in the plant are modified significantly, unless suspended or withdrawn by FQC Standard Uygunluk Degerlendirme A. Ş. The validity of the document is ensured by annual audits.

- Dimension and Shape Tolerances -Yield Strength -Tensile Strength -Elongation	Product	General Conductions	Specific Conductions		Dimensions	Alloy
			Mechanical Specifinations	Tolarance		
	Extrude Profile	EN 755-1	EN 755-2	EN 755-9	Thickness min 0.9 mm. Thickness max. 20.0 mm.	EN AW 6060 EN AW 6063 EN AW 6463



## 19234400 Bitumen Schweissteller

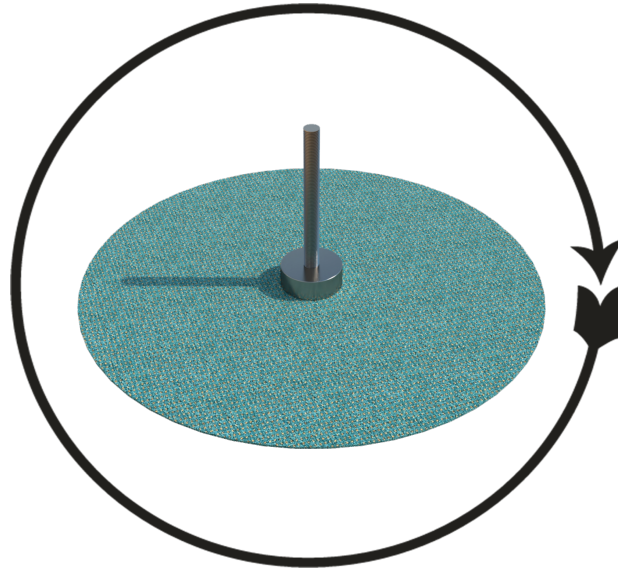

Bitumen Schweissteller  
STAHL + BITUMEN

Bezeichnung	Material	Oberfläche	Stück/ Karton	Verpackung LXBXH	kg/ Stück
Bitumen Schweissteller	Stahl + Bitumen	Pulverbeschichtet	42	120X80X25 cm	0,894

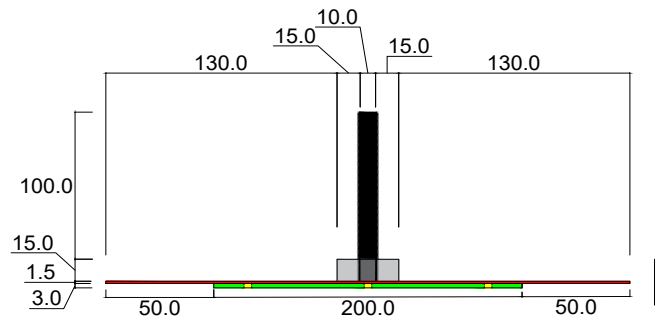
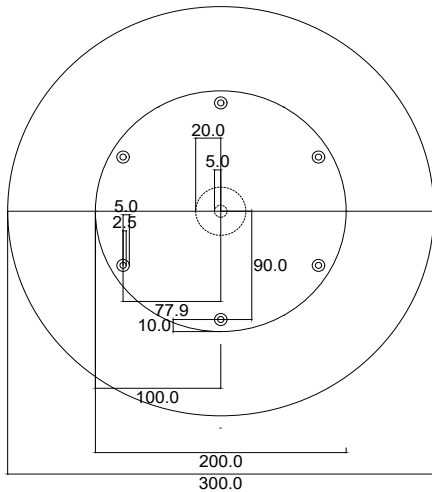

CERTIFIKATE OF CONFORMITY OF THE FACTORY PRODUCTION CONTROL  
2674-CPR-233541

In compliance with Regulation (EU) No 305/2011 of the European Parliament and of the Council of 9 March 2011 (the Construction products Regulation od CPR), this certificate applies to the construction products.

CONSTRUCTION PRODUCT(S)

Scope of certificate : Aluminium and aluminium alloys-Structural products for construction Works

EN 150088:2005

under system 2+ are applied that

the factory production control is assessed to be conformity with the applicable requirements.

This certificate was first issued on <20.12.2023> and will remain valid as long as neither the harmonised standard, the construction product, the AVCP methods nor the manufacturing conditions in the plant are modified significantly, unless suspended or withdrawn by FQC Standard Uygunluk Degerlendirme A. Ş. The validity of the document is ensured by annual audits.

- Dimension and Shape Tolerances -Yield Strength -Tensile Strength -Elongation	Product	General Conditions	Specific Conditions		Dimensions	Alloy
			Mechanical Specifications	Tolerance		
	Extrude Profile	EN 755-1	EN 755-2	EN 755-9	Thickness min 0.9 mm. Thickness max. 20.0 mm.	EN AW 6060 EN AW 6063 EN AW 6463





ARM  
ALUMINYUM



Çerkeşlii mevki imes osb 9.cadde no 19  
dilovası / Kocaeli  
Telefon: +90 533 651 17 66  
Mail : info@armaluminyum.com  
Web: www.armaluminyum.com